

BI-1746 Manual Allen-Bradley SLC™ Backplane Module

BALOGH

7699 Kensington Court
Brighton, MI 48116-8561
(248) 486-7343

Notes are used to call attention to information that is significant to the understanding and operation of equipment.

This BALOGH manual is based on information available at the time of its publication. We have attempted to provide accurate and up-to-date information. This document does not purport to cover all details or variations in hardware or software; nor does it provide for every possible combination of products. Some features described herein may not be available on all like products. BALOGH assumes no obligation to notify holders of this document of any subsequent changes. For the latest up-to-date information and specifications on BALOGH products, contact the BALOGH web site at: www.balogh-group.com

BALOGH makes no representation or warranty, expressed, implied or statutory with respect to, and assumes no responsibility for the accuracy, completeness, or usefulness of the information contained in this manual. No warranties of merchantability or fitness for purpose shall apply.

This product incorporates technology that is licensed by Allen-Bradley Company, Inc. Allen-Bradley has not technically approved, nor does it warrant or support this product. All warranty and support for this product and its application is provided solely by BALOGH, Inc. The ™ symbol represents a trademark of its respective company.

Revision: August 20, 2002 © Copyright BALOGH 2000

Table of Contents

Introduction.....	page: 2
Electrical characteristics.....	3
BI-1746 wiring diagram.....	4
Connection to BALOGH Transceivers.....	6
PLC configuration.....	7
BI-1746 command structure.....	8
BI-1746 commands.....	14
BI-1746 error codes.....	23
TAG addressing.....	23
Data sheet.....	24-25

Introduction

Description

The BI-1746 is a BALOGH RFID backplane plug-in module for the Allen-Bradley SLC-500™ programmable controller family with 1746 backplane. Using technology licensed by the Allen-Bradley Company, the BI-1746 is compatible mechanically with the 1746 backplane chassis and electrical backplane connections. The BI-1746 appears as a specialty I/O interface module to the host CPU and uses interface methods similar to other Allen-Bradley specialty I/O modules.

The BI-1746 allows the PLC to interface with the complete line of BALOGH passive Read/Write and Read Only series RFID TAGS. The BI-1746 gives the user a fast and simple means to manage data on a TAG without the need for extensive ladder logic or the requirement of learning the characteristics of yet another programmable device.

The BI-1746 is equipped with two Transceiver channels that each allow for the connection of a BALOGH Transceiver. Each Transceiver channel operates independently of the other channel. The Transceiver connection is made through a removable wiring terminal block at the front of the unit.

The BI-1746 is also equipped with two RS-232 serial ports. One port is a general-purpose serial port that can be used to move serial data to and from the BI-1746. The second serial port provides the ability to upgrade the BI-1746 flash program memory.

BI-1746 Features:

- Direct rack mount interface for the Allen-Bradley SLC-500™ 1746 PLC
- Two independent Transceiver channels
- User serial port
- Flash utility serial port
- Field upgradeable Flash program memory
- Battery backed SRAM memory
- Simple instruction set
- Module status LED
- Module power LED
- Serial port activity LED
- Dynamic TAG presence indication LED
- Transceiver / Instruction fault LED
- Command execution status LED

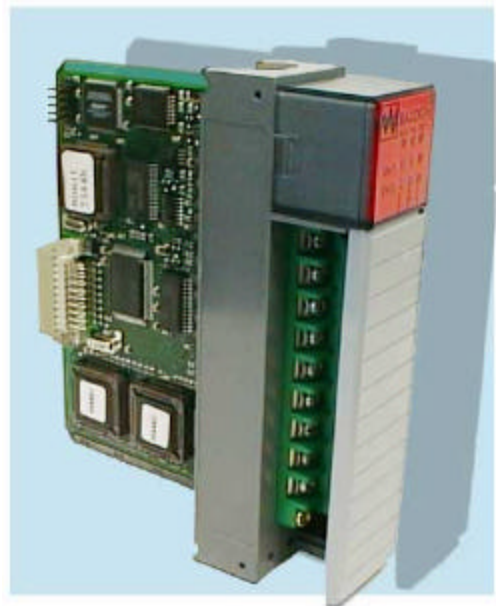

Electrical Characteristics

BI-1746 Power Requirements from SLC™ Modular Chassis and Power Supply

The BI-1746 requires 5 VDC that is provided via the backplane chassis and power supply to support internal circuitry. Please refer to the SLC 500™ Modular Hardware Style Installation and Operation Manual for information concerning the selection of a 1746 power supply.

Voltage: + 5 VDC
 Maximum Current Consumed: 200 mA @ 5 VDC

BI-1746 Power Requirements from External User Power Supply

The BI-1746 requires a separate 24 VDC linear voltage regulated power supply. This supply is required for the circuitry that drives the external hardware resources (Transceivers, serial port). External hardware resources are optically isolated from internal backplane support circuits.

Type: Linear Voltage Regulated
 Voltage: 24 VDC
 Tolerance: +/- 2% DC or better
 Input Frequency Range: 48 - 62 Hz minimum
 Output Ripple: 250 mV p-p at full load

Maximum Current Consumption from external supply with two Transceivers attached.
 Maximum Current Consumed 350 mA @ 24VDC.

External Power supply connection:

Terminal	Connection	Description
17	+ 24 VDC	Power Supply
18	0 VDC	Supply Common

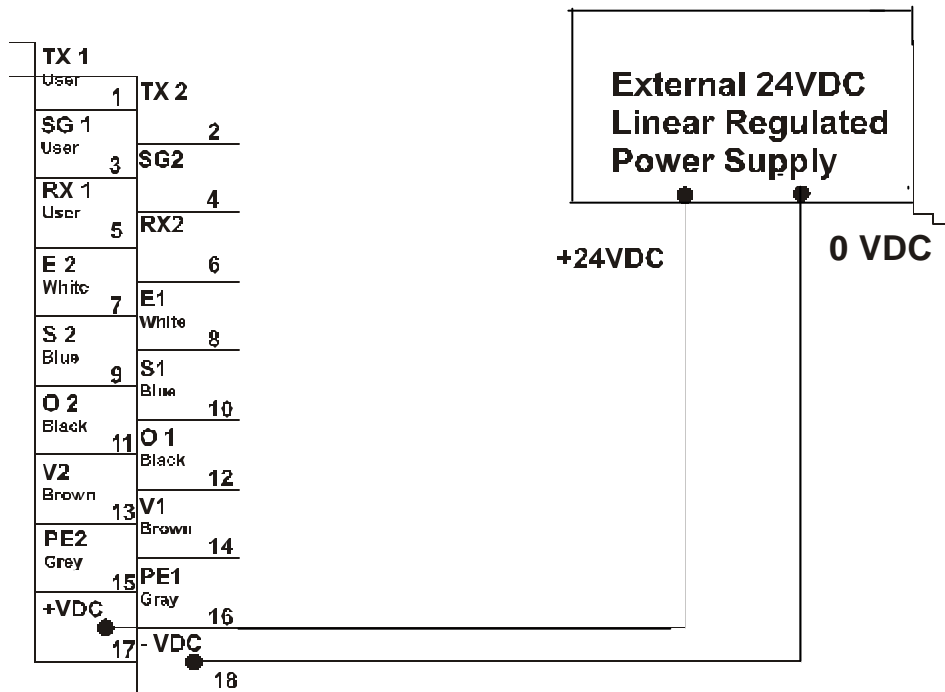

BI-1746 Wiring Diagram

Terminal Block:

Terminal Block Connections		
Terminal	Description	Color Code BALOGH Cabling
1	TX1 RS-232 TXD	
2	TX2 RS-232 TXD	
3	SG1 Signal Ground 1	
4	SG2 Signal Ground 2	
5	RX1 COM1 RS-232 RXD	
6	RX2 COM2 RS-232 RXD	
7	E2 E Channel 2	White (Pin 2) FC-Female
8	E1 E Channel 1	White (Pin 2) FC-Female
9	S2 S Channel 2	Blue (Pin 3) FC-Female
10	S1 S Channel 1	Blue (Pin 3) FC-Female
11	O2 O Channel 2	Black (Pin 4) FC-Female
12	O1 O Channel 1	Black (Pin 4) FC-Female
13	V2 V Channel 2	Brown (Pin 1) FC-Female
14	V1 V Channel 1	Brown (Pin 1) FC-Female
15	PE2 PE Channel 2	Bare (Pin 5) FC-Female
16	PE1 PE Channel 2	Bare (Pin 5) FC-Female
17	+ 24 VDC	Power Supply
18	0 VDC	Supply Common

RS-232 Terminal Definitions:

TX1	- User serial output
TX2	- Flash utility serial output
Signal Ground 1	- Signal ground for user serial port
Signal Ground 2	- Signal ground for flash utility serial port
RX1	- User serial input
RX2	- Flash utility serial input

Transceiver Terminal Definitions:

E	- Transceiver serial communications input
S	- Transceiver serial communications output
O	- Transceiver ground
V	- Transceiver 24VDC power
PE	- Physical earth (Shield connection)

Power Terminal Definitions:

+24 VDC	- Linear regulated 24 Volt DC power supply
0 VDC	- Power supply common

LED Indicators:

The front panel of the BI-1746 contains 9 status LED indicators that provide confirmation of the modules operational state and status of hardware resources.

LED	Color	Description
ACK	Bicolor	Flashes green when user serial port is active. Solid red in the event of a timeout or overflow
PWR	Bicolor	Green when internal Backplane +5 VDC power is applied. Flashing Green during flash memory programming. Flashing Red/Green during flash memory erase. Off when no Backplane power applied.
OK	Bicolor	Green when module in RUN state. Red when module in STOP state.
EXE	Green	On while a command is executing.
PRE	Green	On when a TAG is present in Transceivers Transmission Zone.
FLT	Red	On steady Transceiver fault /TAG ram fault On momentarily Execution fault / Timeout

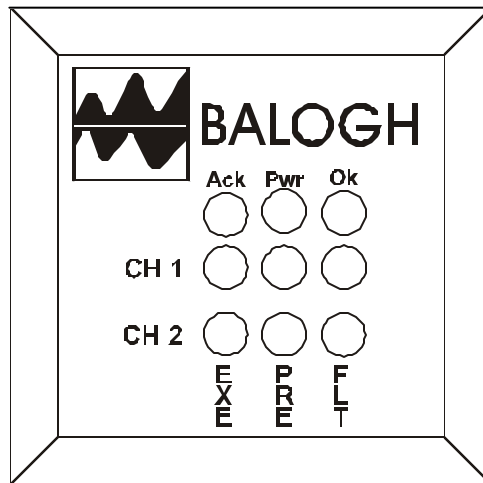

Connection to BALOGH Transceivers

Each BALOGH Transceiver is equipped with a factory installed 5 pin male quick connector. The mating female connector and cable assembly recommended for use is BALOGH'S polyurethane outer jacketed twin pair twisted / shielded cables. This is a molded 5-pin female connector available in either straight or right-angled configurations. The maximum distance between a Transceiver and the BI-1746 is specified on the Transceiver data sheet. Guidelines for installation are provided in the BALOGH Assembly Manual. Please consult the BALOGH Product guide for details regarding standard cable lengths.

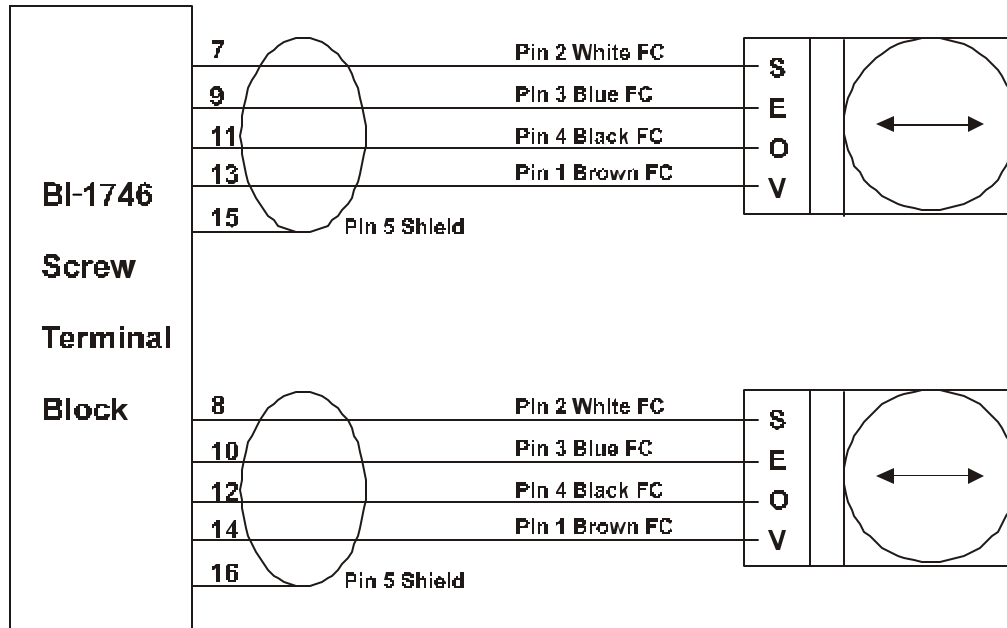

NOTES:

1. The shield connection between the screw terminal block and the cable must be protected to prevent contact with nearby terminals or wiring. Shrink-wrapping this connection is suggested.
2. Retrofits and custom wire lengths:
For existing applications or applications that require cable lengths that are not standard an alternate 5-pin female field connector is available. The drawing below depicts the wiring schematic used when connecting to a BALOGH QC Transceiver.

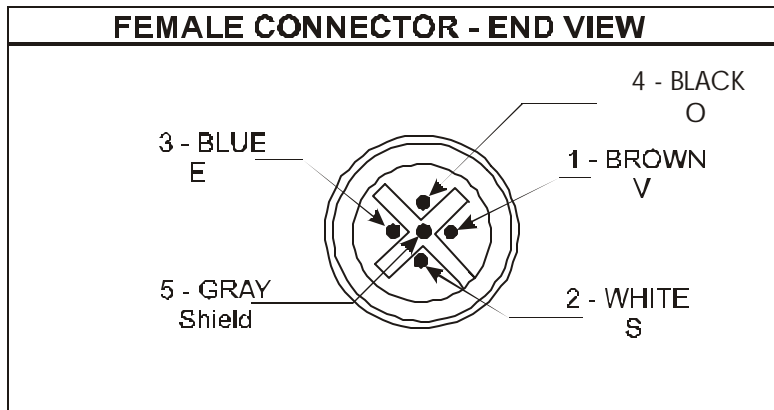

PLC Configuration

The PLC project folder must be configured to recognize the BI-1746. This is accomplished using either RSLogic 500™ or APS™ programming software. The BI-1746 utilizes 32 words of input, 32 words of output and 6144 words of M1 / M0 file memory.

The following steps describe how the configuration is achieved using RSLogic 500™ revision 2.10.12.0.

- Open project folder (offline)
- Open controller folder
- Select I/O configuration
- In current cards available list box highlight: Other- Requires I/O Card Type ID
- Drag & Drop this selection to the desired slot location.
- The "Other" type I/O card dialogue box will prompt for the BI-1746 ID number.
- Enter 13635 (BI-1746 ID Number).
- Double click on: Other I/O Module Code = 13635
- The advanced I/O Configuration dialogue box will appear.

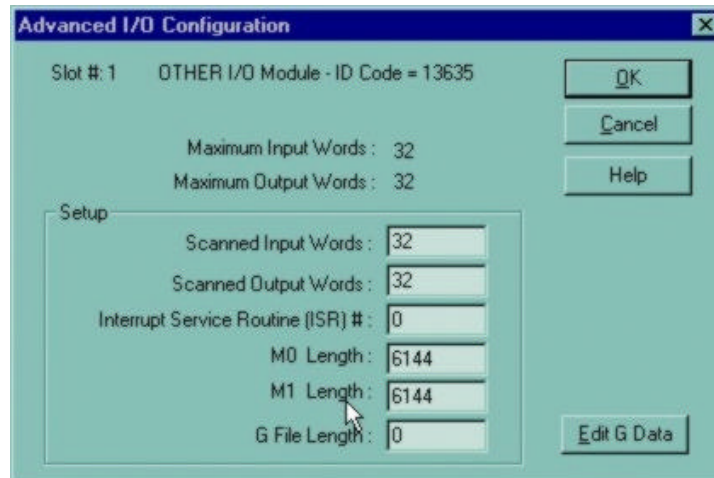

Enter the following data:

- Scanned Input Words 32
- Scanned Output Words 32
- Interrupt Service Routine # 0
- M0 Length 6144
- M1 Length 6144
- G file Length 0

BI-1746 Command Structure

Command Summary

Command	Instruction	Parameter 1	Parameter 2	Parameter 3	Parameter 4	Parameter 5
Block TAG Write	1(01h)	Channel	Number bytes	TAG Address	M0 File Offset	Timeout
Block TAG Read	2(02h)	Channel	Number of bytes	TAG Address	M1 File Offset	Timeout
Discontinuous TAG Read	3(03h)	Channel	Not Used	Not Used	M0 File Offset *	Timeout
Fill TAG	4(04h)	Channel	Number of bytes	TAG Address	Fill Value	Timeout
Reset Request	5(05h)	Channel	Not Used	Not Used	Not Used	Not Used
Discontinuous TAG Write	6(06h)	Channel	Not Used	Not Used	M0 File Offset *	Timeout
Configure Serial Port	7(07h)	Channel	Not Used	Not Used	SM Parameter	Not Used
Serial Port Read	11(0Bh)	Channel	Number of bytes	Not Used	M1 File Offset	Timeout
Serial Port Write	12(0Ch)	Channel	Number of bytes	Not Used	M0 File Offset	Not Used

* Note: The M0 file location indicates the Start of the Discontinuous Control Block (DCB).

Module Functional Description:

The BI-1746 is designed to control up to (2) BALOGH Transceivers and one user serial port. To manage these resources the BI-1746 is equipped with a basic set of instructions. These instructions consist of commands to read and write data to BALOGH TAGS and manage data transfers related to the user serial port. The PLC communicates to the BI-1746 resources by placing command requests in one of five available command execution fields arranged in the Output Image Table. The first command field has the highest priority, the last field the lowest. Up to five commands can be requested at any one time.

The BI-1746 will allow each Transceiver channel to operate independent and simultaneous of the other. This means that a command request may be issued in Command Field 1 and that directs channel one to read with wait. While channel one is waiting for a TAG'S arrival, the remaining Command fields are available to execute commands at channel two and the serial port.

Addressing Data and Commands

The BI-1746 module uses four memory areas for communicating with a PLC. The Input and Output Image Tables are used for passing command execution status results and issuing command execution requests. The M1 and M0 files are used to store and retrieve data as required by parameters defined in the command request.

SLC™ Output Image Table	Flags and Command requests sent from the PLC to the BI-1746.
SLC™ Input Image Table	Module status and Command Status Results sent from the BI-1746 to the PLC.
SLC™ M0 Output Data Table	Where the PLC will write data and format fields to the BI-1746.
SLC™ M1 Input Data Table	Where the PLC will read data from the BI-1746.

Command Requests:

A Command Request is made up of an instruction word and five related parameter words. The command request is issued to the BI-1746 through command fields defined in the layout of the Output Image Table. The BI-1746 monitors the first word of each command request field. When a valid instruction is placed in the first word of a command field the BI-1746 will start the execution of the command. To minimize PLC instructions the user can pre-load the parameter words of each required command request field upon initialization of the PLC program.

Issuing a Command Request:

To issue a command request, move or copy the instruction number and related parameters to a Command Request field in the Output Image Table and copy data and /or format information to the M0 table as required by the command.

The users PLC logic should then monitor the execution bit located in the corresponding Command Status result word in the Input Image Table. The execution bit, which is the MSB of the lower byte, will transition from high (1) to low (0), this is the BI-1746'S indication that the command has been accepted. Once the execution bit is low, the instruction request field must be cleared to zero. This will prevent multiple executions of the command request. The BI-1746 will indicate the completion of the command by placing the execution bit to one (1). At this time, the Input Image Table will contain an updated Command Status Result word and the M1 table will contain any data that is related to the command.

Output Image Table:

The BI-1746 uses the 32-word output image file associated with the module for controlling the modules state and for passing command requests. Control of the BI-1746 activity state (Running or Idle) is achieved through Word 0, the Module Control Word. Command requests are passed to the BI-1746 using the remaining 31 words.

Output Image Table				
Word	Description	Word	Description	
0:X.0	Module Control Word	0:X.16	Command-3, Parameter 3	
0:X.1	Command Request-1, Instruction	0:X.17	Command-3, Parameter 4	
0:X.2	Command-1, Parameter 1	0:X.18	Command-3, Parameter 5	
0:X.3	Command-1, Parameter 2	0:X.19	Command Request 4, Instruction	
0:X.4	Command-1, Parameter 3	0:X.20	Command-4, Parameter 1	
0:X.5	Command-1, Parameter 4	0:X.21	Command-4, Parameter 2	
0:X.6	Command-1, Parameter 5	0:X.22	Command-4, Parameter 3	
0:X.7	Command Request-2, Instruction	0:X.23	Command-4, Parameter 4	
0:X.8	Command-2, Parameter 1	0:X.24	Command-4, Parameter 5	
0:X.9	Command-2, Parameter 2	0:X.25	Command Request 5, Instruction	
0:X.10	Command-2, Parameter 3	0:X.26	Command-5, Parameter 1	
0:X.11	Command-2, Parameter 4	0:X.27	Command-5, Parameter 2	
0:X.12	Command-2, Parameter 5	0:X.28	Command-5, Parameter 3	
0:X.13	Command Request-3, Instruction	0:X.29	Command-5, Parameter 4	
0:X.14	Command-3, Parameter 1	0:X.30	Command-5, Parameter 5	
0:X.15	Command-3, Parameter 2	0:X.31	Reserved	

X = BI-1746 slot location in main rack.

Input Image Table:

The BI-1746 uses the 32 word input image file associated with the module for the purpose of reporting the modules status, the dynamic status of each Transceiver channel and reporting the execution status of command requests.

Input Image Table	
Word	Description
I:X.0	Module Status
I:X.1	Dynamic Status Channels 1 & 2
I:X.2	Command-1 Status Result
I:X.3	Command-2 Status Result
I:X.4	Command-3 Status Result
I:X.5	Command-4 Status Result
I:X.6	Command-5 Status Result
I:X.7	Serial Read Status Result
I:X.8	Number of bytes Received
I:X.9	Serial Write Status Result
I:X.10	Number of bytes Transmitted
I:X.11	Serial Port Configure Status Result
I:X.12-31	Reserved

X = BI-1746 slot location in main rack.

Useful Bit Locations		
I:X/39	I:X.2/7	Command Status 1 Execution Bit
I:X/55	I:X.3/7	Command Status 2 Execution Bit
I:X/71	I:X.4/7	Command Status 3 Execution Bit
I:X/87	I:X.5/7	Command Status 4 Execution Bit
I:X/103	I:X.6/7	Command Status 5 Execution Bit
I:X/119	I:X.7/7	Serial Port Read Status Result Execution Bit
I:X/151	I:X.9/7	Serial Port Write Status Result Execution Bit
I:X/183	I:X.11/7	Serial Port Configure Status Result Execution Bit

X = BI-1746 slot location in main rack.

Module Status Result Word

Module Status Result Word 0	
Bit	Description
0	1 = Run 0 = Stop
1	1 = Invalid Channel requested
2	1 = Invalid Instruction Code
3 -15	Reserved

Word 1 Input Image:

Dynamic Status Word

The dynamic status is a continuously updated word that contains the status of each Transceiver channel regardless of the execution state of the channel. This data is useful for monitoring the state of each Transceiver channel and determining the presence or absence of a TAG without the need for an externally hard-wired input.

Dynamic Status Word 1					
	Bit	Wordwise	Bitwise	Name	Description
C H A N N E L 1	0	I:X.1/0	I:X/16	Specific Fault (bits 0-3)	Description of Specific Fault
	1	I:X.1/1	I:X/17	Specific Fault (bits 0-3)	Description of Specific Fault
	2	I:X.1/2	I:X/18	Specific Fault (bits 0-3)	Description of Specific Fault
	3	I:X.1/3	I:X/19	Specific Fault (bits 0-3)	Description of Specific Fault
	4	I:X.1/4	I:X/20	General Fault	1 = Fault or Timeout
	5	I:X.1/5	I:X/21	TAG Present	1 = TAG Present
	6	I:X.1/6	I:X/22	Low Battery	1 = Battery Low *
1	7	I:X.1/7	I:X/23	Execution Status	1 = Execution Complete
C H A N N E L 2	8	I:X.1/8	I:X/24	Specific Fault (bits 0-3)	Description of Specific Fault
	9	I:X.1/9	I:X/25	Specific Fault (bits 0-3)	Description of Specific Fault
	10	I:X.1/10	I:X/26	Specific Fault (bits 0-3)	Description of Specific Fault
	11	I:X.1/11	I:X/27	Specific Fault (bits 0-3)	Description of Specific Fault
	12	I:X.1/12	I:X/28	General Fault	1 = Fault or Timeout
	13	I:X.1/13	I:X/29	TAG Present	1 = TAG Present
	14	I:X.1/14	I:X/30	Low Battery	1 = Battery Low *
2	15	I:X.1/15	I:X/31	Execution Status	1 = Execution Complete

* Not applicable to the batteryless Read/Write series of TAGS.

When reading the "OF" style Fixed Code TAG, this bit is used to indicate that the new TAG data read is different from the last TAG data read.

Specific Fault Codes:

The following table of fault codes is valid when the general fault bit of the status result is set to one.

Specific Error Description	
Fault Code	Meaning
01 Hex	Invalid Data Length
05 Hex	Internal channel communications fault
0B Hex	Invalid TAG address requested
0C Hex	Transceiver fault
0E Hex	TAG memory fault
0F Hex	TAG dialogue fault

Input Image Words 2- 6

Command Status Result Word

This word provides the result of the command that has been executed. This word also includes the Command Execution Status bit, which is used for verifying the execution of a command. This bit is initially high at power up and will transition low when a command has been accepted by the BI-1746. Upon completion of the command, it will return high. At that time, all other status bits will also be valid. The command status result is held until the execution of the next command or loss of power.

Command Status Result Word 2 - 6			
C O M M A N D S T A T U S	Bit	Name	Description
	0	Specific Fault (bits 0-3) bits3333	Description of Specific Fault
	1	Specific Fault (bits 0-3)	“ ”
	2	Specific Fault (bits 0-3)	“ ”
	3	Specific Fault (bits 0-3)	“ ”
	4	General Fault	1 = Fault or Timeout
	5	TAG Present	1 = TAG Present
	6	Low Battery	1 = Battery Low [?]
	7	Execution Status	1 = Execution Complete
	8 -15	Reserved	

Specific Fault Codes:

The following table of fault codes is valid when the general fault bit of the status result is set to one.

Specific Error Description	
Fault Code	Meaning
05 Hex	Internal channel communications fault
0B Hex	Invalid TAG address requested
0C Hex	Transceiver fault
0E Hex	TAG memory fault
0F Hex	TAG dialogue fault or Timeout
01 Hex	Invalid Data Length

BI-1746 Commands

TAG Block Write Command Instruction Number 1 (01h)

The TAG block write command will write a block of consecutive data to the TAG. The TAG at the Transceiver Channel specified in word 1 is written starting at the address specified at word 3 with the amount of data specified at word 2. The data to write is retrieved from the M0 file offset (given in bytes). Word 5 specifies the timeout value. This parameter has a valid range from 0 to 65535. A value of zero indicates read with wait, any value other than zero will institute a timeout calculated as 10 ms* timeout value.

Word	Description
0	Command code 1 (01h)
1	Transceiver Channel number (1, 2)
2	Number of bytes to write
3	TAG starting address
4	M0 - file offset, in bytes
5	Timeout, 10 ms resolution, to read all data, 0 = with wait

TAG Block Read Command Instruction Number 2 (02h)

The TAG block read command allows for a block of consecutive data to be read from a TAG. Upon issuing this command, the TAG at the Transceiver channel specified in word 1 is read, beginning at the starting address specified at word 3. The data length specified at word 2 is then returned to the M1 file offset (in bytes) specified at word 4. Word 5 specifies the timeout value. This parameter has a valid range from 0 to 65535. A value of zero indicates read with wait, any value other than zero will institute a timeout calculated as 10 ms* timeout value.

Word	Description
0	Command code 2 (02h)
1	Transceiver Channel number (1, 2)
2	Number of bytes to read
3	TAG starting address
4	M1 - file offset, in bytes
5	Timeout, 10 ms resolution, to read all data, 0 = with wait

Discontinuous TAG Read Command

Instruction Number 3 (03h)

The TAG Discontinuous Read Command allows for the reading of TAG data that is scattered throughout the TAG. Upon issuing this command, the TAG at the Transceiver Channel specified in word 1 will be read. The data will then be placed at the M1 file locations specified in the DCB (Discontinuous Control Block). Word 4 is an M0 file offset (in bytes) to the location of the DCB. Word 5 specifies the timeout value. This parameter has a valid range from 0 to 65535. A value of zero indicates Read with Wait, any value other than zero will institute a timeout calculated as 10 ms * timeout value.

Word	Description
0	Command code 3 (03h)
1	Transceiver Channel Number (1,2)
2	Not used
3	Not used
4	M0 - file offset, in bytes of the DCB
5	Timeout, 10 ms resolution, to read all data, 0 = with wait

Command Status Result Word

The Command Status Result Word will clear the execution bit (bit 7) at the start of this command and return this bit to one upon completion/timeout or error. At this time, the Command Status Result Word will contain the new Status Result. See the Command Status Result Word for specific details.

DCB Discontinuous Control Block

The Discontinuous Control Block defines the range of data fields that will be read from the TAG. The maximum number of fields is sixteen (16) with a total number of data bytes in all fields not to exceed 128 bytes. The DCB is defined as follows, Word 1 specifies the start address to begin reading, Word 2 specifies the number of bytes to read, Word 3 is the offset (in bytes) to the M1 file location where the read data will be placed. All fields should follow each other consecutively in memory with the last field followed by three words of zero, when less than 16 fields are utilized.

Discontinuous Control Block			
Field 1	Word 1	Word 2	Word 3
	TAG Start Address	Number of bytes	M1- File to place read data
Field 16	Word 46	Word 47	Word 48
	TAG Start Address	Number of bytes	M1- File to place read data

TAG Fill Command Instruction Number 4 (04h)

The TAG Fill Command will write a consecutive number of TAG addresses with the fill value. Upon issuing this command, the TAG at the Transceiver Channel specified in word 1 will be filled starting at the TAG address specified at word 3. The fill value specified in word 4 will be repeated throughout the length set in word 2. Word 5 specifies the timeout value. This parameter has a valid range from 0 to 65535. A value of zero indicates read with wait, any value other than zero will institute a timeout calculated as 10 ms* timeout value.

Word	Description
0	Command code 4 (04h)
1	Transceiver Channel Number (1, 2)
2	Number of bytes
3	TAG address
4	Fill value (data to write on TAG)
5	Timeout, 10 ms resolution, to read all data, 0 = with wait

Reset Request Command Instruction Number 5 (05h)

The Reset Request Command allows for a pending TAG operation to be canceled or the serial input buffer to be flushed. Upon issuing this command, any TAG operation pending at the channel specified in Word 1 will be canceled.

Word	Description
0	Command code 5 (05h)
1	Transceiver Channel Number (1, 2, 3)
2	Reserved
3	Reserved
4	Reserved
5	Reserved

Discontinuous TAG Write Command Instruction Number 6 (06h)

The Discontinuous TAG Write Command allows for the writing of TAG data that is scattered throughout the TAG. Upon issuing this command, the TAG at the Transceiver Channel specified in word 1 will be written. The data fields to be written are defined in the DCB (Discontinuous Control Block). Word 4 is an M0 file offset (in bytes) to the location of the DCB. Word 5 specifies the timeout value. This parameter has a valid range from 0 to 65535. A value of zero indicates read with wait, any value other than zero will institute a timeout calculated as 10 ms* timeout value.

Word	Description
0	Command code 6 (06h)
1	Transceiver Channel Number (1, 2)
2	Not used
3	Not used
4	M0 - file offset, in bytes of the DCB
5	Timeout, 10 ms resolution, to read all data, 0 = with wait

Command Status Result Word

The Command Status Result Word will clear the execution bit (bit 7) at the start of this command and return this bit to one upon completion/timeout or error. At this time, the Command Status Result Word will contain the new status result. See the Command Status Result word for specific details.

DCB Discontinuous Control Block

The Discontinuous Control Block defines the range of data fields that will be written to the TAG. The maximum number of fields is 16 with a total number of data bytes in all fields not to exceed 128 bytes. The DCB is defined as follows, Word 1 specifies the start address to begin writing, Word 2 specifies the number of bytes to write, Word 3 is the offset (in bytes) to the M0 file location where the data to write is located. All fields should follow each other consecutively in memory with the last field followed by three words of zero when less than 16 fields are utilized.

Discontinuous Control Block			
Field 1	Word 1	Word 2	Word 3
	TAG Start Address	Number of bytes	M0- File location of data to write
Field 16	Word 46	Word 47	Word 48
	TAG Start Address	Number of bytes	M0- File location of data to write

Configure Serial Port Instruction Number 7 (07h)

The Configure Serial Port command request will set the communication parameters for the User Serial Port. The User Serial Port is designated as Channel number 3. The Serial Message Parameter that is issued in Word 4 of this command request defines the new baud rate, parity, data bits and stop bits that will be applied to any subsequent communications. The default configuration for the User Serial Port after startup is 9600 baud, 8 data bits, and 1 stop bit with no parity.

Word	Description
0	Command code 7 (07h)
1	User Serial Port Channel Number (3)
2	Not used
3	Not used
4	Serial Message Parameter
5	Not used

Status Result Word:

The Status Result Word associated with this command is located in the input image file Word 11. The execution bit will transition from high (1) to low (0) at the start of this command request. Upon completion, the execution bit will return high (1). There are no errors associated with this command.

Serial Message Parameter

Bit	Description								
0	Baud rate	19200	9600	4800	2400	1200	600	300	150
1		0	1	0	1	0	1	0	1
2		0	0	1	1	0	0	1	1
3	Not used								
4	Data bits	0 = 8 bits 1 = 7 bits							
5	No. Stop bits	0 = 1 stop 1 = 2 stop							
6	Parity	0 = with parity 1 = without parity							
7	Type of Parity	0 = even parity 1 = odd parity							

Example:

SM Parameter = 81 Hex

This SM parameter will establish communications of 9600 baud, with odd parity, eight data bits and one stop bit.

Input Image Word 11:

Serial Port Configuration Status Word

Serial Port Configuration Status Result					
C O M M A N D S T A T U S	Bit			Name	Description
	0			Reserved	
	1			Reserved	
	2			Reserved	
	3			Reserved	
	4			Reserved	
	5			Reserved	
	6			Reserved	
	7	I:X/183	I:X.11/7	Execution Status	1 = Execution Complete
	8 -15			Reserved	

User Serial Port Read Command**Instruction Number 11 (0Bh)**

The Read User Serial Port Command will open the user serial port for the reception of serial characters. The user serial port is designated as Channel 3. The number of bytes to receive is specified in Word 2 with the maximum reception length being 1024 bytes. The data received will be stored in the M1file offset specified in Word 4. Word 5 specifies a timeout value. This parameter has a valid range from 0 to 65535 and a resolution of 1 ms.

Word	Description
0	Command code 11 (0Bh)
1	User Serial Port Channel Number (3)
2	Number of bytes to receive
3	High byte = starting character / Low byte = ending character
4	M1 - file offset, in bytes
5	Timeout, 1 ms resolution

Serial Port Read Status Result:

The Status Result Word associated with this command is located at input image file Word 7. The execution bit will transition from high (1) to low (0) at the start of this command. Upon completion, timeout, or error, the execution bit will return high (1) and the value of the total number for bytes received will be updated and placed at word 8 of the input image.

Serial Port Read Status Result Word 7					
C O M M A N D S T A T U S	Bit			Name	Description
	0			Specific Fault (bits 0-3)	Description of Specific Fault
	1			Specific Fault (bits 0-3)	“ ”
	2			Specific Fault (bits 0-3)	“ ”
	3			Specific Fault (bits 0-3)	“ ”
	4	I:X/116	I:X.7/4	General Fault	1 = Fault or Timeout
	5			Reserved	
	6			Reserved	
	7	I:X/119	I:X.7/7	Execution Status	1 = Execution Complete
8 -15			Reserved		

Specific Fault Codes:

The following table of fault codes is valid when the general fault bit of the status result is set to one.

Specific Error Description Word 8	
Fault Code	Meaning
08 Hex	Serial buffer overflow
09 Hex	Serial read timeout

Input Image Word 8:

Number of bytes received

Serial Port Read- Number of bytes	
Word	Description
8	Number of bytes received

User Serial Port Write Command**Instruction Number 12 (0Ch)**

The User Serial Port Write command will initiate the transmission of characters from the user serial port. The user serial port is designated as Channel 4. The number of bytes to transmit is specified in Word 2 with the maximum transmission length being 1024 bytes. The data to transmit will be retrieved from the M0 file offset specified in word 4.

Word	Description
0	Command code 12 (0Bh)
1	User Serial Port Channel Number (4)
2	Number of bytes to transmit
3	Not used
4	M0 - file offset, in bytes
5	Not used

Serial Port Write Status Result:

The Status Result Word associated with this command is located at input image file Word 9. The execution bit will transition from high (1) to low (0) at the start of this command. Upon completion the execution bit will return high (1) and the value of the total number for bytes transmitted will be updated placed at Word 10 of the input image file. There are no errors related to this command.

Serial Port Write Status Result Word 9					
C O M M A N D S T A T U S	Bit			Name	Description
	0			Reserved	
	1			Reserved	
	2			Reserved	
	3			Reserved	
	4			Reserved	
	5			Reserved	
	6			Reserved	
	7	I:X/151	I:X.9/7	Execution Status	1 = Execution Complete
	8 -15			Reserved	

Input Image Word 10

Number of bytes transmitted

Serial Port Write - Number of bytes	
Word	Description
10	Number of bytes transmitted

BI-1746 Error Codes

Specific Error Description

Fault Code	Meaning
01 Hex	Invalid Data Length Fault
05 Hex	Internal Channel Communication Fault
0B Hex	TAG Address Fault
0C Hex	Transceiver Fault
0E Hex	TAG Memory Fault
0F Hex	TAG Dialogue Fault

TAG Addressing:

TAG Type	Address in bytes (Decimal)
OF Fixed Code 7 byte	0 to 6
OMA 64 byte	2048 to 2111
OMA 2K byte	0 to 2047
OMA 8K byte	0 to 8180
OMX 8K byte	0 to 8180
OMX 32K byte	0 to 32767
GIE 512 byte	0 to 511
GIE 2K byte	0 to 2047
GIE 8K byte	0 to 8180
OP 96 byte	(Read) 0-3 Serial Number / (Write) 12-15 Serial Number- 4-95 User Data (Locked Cannot Change) 16-107 User Data



BI-1746/** Allen-Bradley SLC® Backplane Module

Identification - Coding

Reference: BI-1746/**

A=	OMA	64, 2K, or 8K bytes Read/Write TAG
P=	OP	64 byte & 96 byte Read/Write
X=	OMX	High Speed 8K & 32K byte Read/Write TAG
E=	GIE	512, 2K, 8K byte Read/Write
F=	OF or OFR	7 bytes Read-Only TAG
L=	OL or OLR	2 byte Read-Only Extended Range TAG

Characteristics

The BALOGH BI-1746/** is an RFID backplane plug-in module for the Allen-Bradley SLC 500 programmable controller. The BI-1746/** allows the PLC to interface with the complete line of BALOGH RFID Passive TAGS. Each module controls up to (2) Transceivers, each operating independently and simultaneously of each other. The BI-1746 has two RS-232 serial ports, one general purpose serial port which can be used to send/receive data. The second serial port provides the ability to upgrade the BI-1746 flash program memory.

The BI-1746/** appears as a specialty I/O interface module to the SLC, with a product I.D. Code of 13635. The BI-1746 receives internal 5 volt DC circuitry power from the backplane chassis. An external 24 volt DC regulated power supply is required for Transceivers, and serial port communications. External hardware devices are optically isolated from internal backplane support circuits.

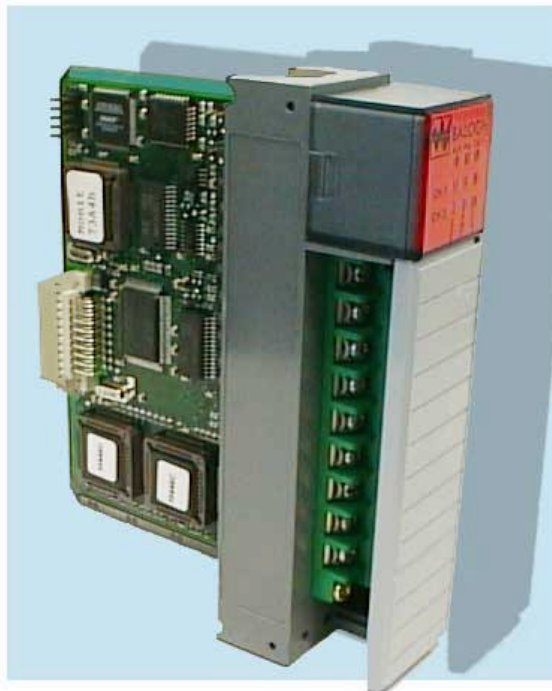

Features

- LED Status Indications for Module Status, Module Power, Serial Port Communications, TAG Presence, Transceiver/TAG Fault, Command Execution
- CE compliant
- User RS-232 Serial Port
- Flash upgrade Serial Port
- Battery backed SRAM Memory
- Controls up to (2) Transceivers
- Easy to use instruction set

External Power	Symbol	Unit	BI-1746
Supply power (+2%, 2%)	Ucc	V	24 VDC (ripple,2%)
Current Consumed	Lo	mA	350mA

BI-1746 Module

Ambient temperature	T	°C	0° to 50° C
Weight	M	G	750 grams
Max. current consumed		mA	200mA
Voltage		V	5 VDC

