

BS-46

BALOGH

7699 Kensington Court
Brighton, MI 48116-8561
(248) 486-7343

Notes are used to call attention to information that is significant to understanding and operating the equipment.

This **BALOGH** BS-46 Manual is based on information available at the time of its publication. Every effort has been made to provide accurate and up-to-date information. This document does not purport to cover all details or variations in hardware or software; nor does it provide for every possible combination of products. Some features described herein may not be available on all like products. **BALOGH** assumes no obligation to notify holders of this document of any subsequent changes. **BALOGH** makes no representation or warranty, expressed, implied or statutory with respect to, and assumes no responsibility for the accuracy, completeness, or usefulness of the information contained in this manual. No warranties of merchantability or fitness for purpose shall apply.

Table of Contents

Introduction.....	page: 1
Reminder About Coding Systems.....	2
Lay Out of the BS-46.....	3
Configuration of the BS-46 Interface.....	4
Electronic Characteristics.....	6
Diagram of Parallel Inputs and Outputs.....	8
Serial Link.....	9
Connection.....	11
Addressing of the BS-46 for Channel #1.....	12
TAG Addressing.....	13
Use of the BS-46.....	14
Standard Operation of the BS-46.....	15
BS-46 with PLC under DF1® & DH+® Protocol.....	17
Overview about the DF1® & DH+® Protocol.....	19
Hardware Configuration.....	19
Software Configuration.....	20
Polling Table.....	22
BS-46 Addressing.....	23
Direct Access Mode (“DA” Mode).....	25
Reading a TAG in “DA” Mode.....	27
Writing to a TAG in “DA” Mode.....	28
Fault Condition in “DA” Mode.....	29
Automatic Reading Mode (“AR” Mode).....	30
Writing to the “AR” Mode Buffer.....	32
Reading the “AR” Mode Buffer.....	33
Contents of Results Buffer in “AR” Mode.....	34
Faults “AR” Mode.....	35
Controlled Operating Mode (“CO” Mode).....	36
Writing to the “CO” Mode Buffer.....	38
Reading from the “CO” Mode Buffer.....	39
Results Buffer “CO” Mode.....	40
Faults “CO” Mode.....	41
Serial Link Operation “CO” Mode.....	42
Parallel Input Operation “CO” Mode.....	43
Operation.....	44
BS-46 with JBUS® / MODBUS® Protocol.....	45
Reminder about the JBUS® / MODBUS® Protocol.....	47
Addressing Under MODBUS® Protocol.....	50
Direct Access Mode (“DA” Mode).....	51
Automatic Reading Mode (“AR” Mode).....	52
Faults.....	54
Controlled Operating Mode (“CO” Mode).....	55
Faults.....	57
BS-46 with SLC 503/504 under DF1® & DH+® Protocol.....	59
Overview about the DF1® & DH+® Protocol.....	61
Hardware Configuration.....	61
Channel 0 Configuration.....	62
Software Configuration.....	63
BS-46 Addressing.....	65
Direct Access Mode (“DA” Mode).....	67
Reading a TAG in “DA” Mode.....	70

Writing a TAG in “DA” Mode.....	71
Fault Condition “DA” Mode.....	72
Automatic Reading Mode (“AR” Mode).....	73
Writing to the “AR” Mode Buffer.....	75
Reading the “AR” Mode Buffer.....	76
Contents of Results Buffer in “AR” Mode.....	77
Faults “AR” Mode.....	78
Controlled Operating Mode (“CO” Mode).....	79
Writing to the “CO” Mode Buffer.....	82
Reading from the “CO” Mode Buffer.....	83
Results Buffer “CO” Mode.....	84
Faults “CO” Mode.....	85
Serial Link Operation “CO” Mode.....	86
Parallel Input Operation “CO” Mode.....	87
Operation.....	88
BS-46 Data Sheet.....	89
Example Lay Out Diagram.....	91

Introduction

The BS-46 Serial Interface Unit controls communication between BALOGH'S electronic TAGS and Transceivers.

- **BS-46:**

- Has one serial link, configurable to: RS-422, RS-485, or RS-232
- Is Dual Channel: 2 Transceivers can both be connected, functioning independently and simultaneously
- Has DIP switches to configure: Communication protocol, slave number, baud rate (up to 19200 baud), and parity even or odd

- **The BS-46 has 3 Operating Modes:**

Direct Access Mode (TAG Reading or Writing) : "DA" Mode

Automatic Read Mode : "AR" Mode

Controlled Operating Mode : "CO" Mode
executes a stored command only if a parallel input or an internal bit is activated. Two commands can be programmed for each Channel.

- **The BS-46 allows dialogue on its 2 Channels with electronic TAG type:**

The BS-46/AA	"	"	"	"	"	"	"OMA"
The BS-46/FF	"	"	"	"	"	"	"OF" & "OFR"
The BS-46/XX	"	"	"	"	"	"	"OMX"
The BS-46/PP	"	"	"	"	"	"	"OP"
The BS-46/EE	"	"	"	"	"	"	"GIE" Series
The BS-46/LL							"OL & OLR"

Reminder about Coding Systems

A Read or Read/Write station is composed of a Transceiver and a logic interface (Control Board). They communicate via BALOGH'S RFID TAGS.

Electronic TAG:

Passive RFID TAGS are independent of a power supply. They receive the necessary energy for operating from an electromagnetic field emitted by a Transceiver.

- TAG "OMA"	Read/Write TAGS. Data is stored in non-volatile Ferro Electric memory.	Capacity:	64 bytes, 2K bytes, or 8K bytes
- TAG "OF/OFR"	Read-Only TAGS. Data is factory programmed to users specifications. OFR TAGS are user re-programmable.	Capacity:	7 bytes
- TAG "OMX"	High-Speed Read/Write TAGS. Data is stored in a non-volatile Ferro Electric memory.	Capacity:	8K bytes or 32K
- TAG "GIE"	Ferro Electric memory	Capacity:	512 bytes, 2K, or 8K bytes
- TAG "OP"	EEPROM memory	Capacity:	64 bytes or 96 bytes
- TAG "OL/OLR"	Read-Only Extended Range TAGS. Data is factory programmed to users specifications. OLR TAGS are user re-programmable.	Capacity:	2 bytes

Transceiver:

The Transceiver communicates with a passive RFID TAG by way of an inductive electromagnetic field emitted by a Transceiver.

- It supplies the necessary energy for TAG operation.
- It provides Transmission of data, which can be Read or Written.

Interface Control Board:

The interface unit controls the operation of the Transceiver and communications with an RFID electronic TAG. The interface unit processes data and is necessary as an interface with the user's host controller.

Lay Out of the BS-46

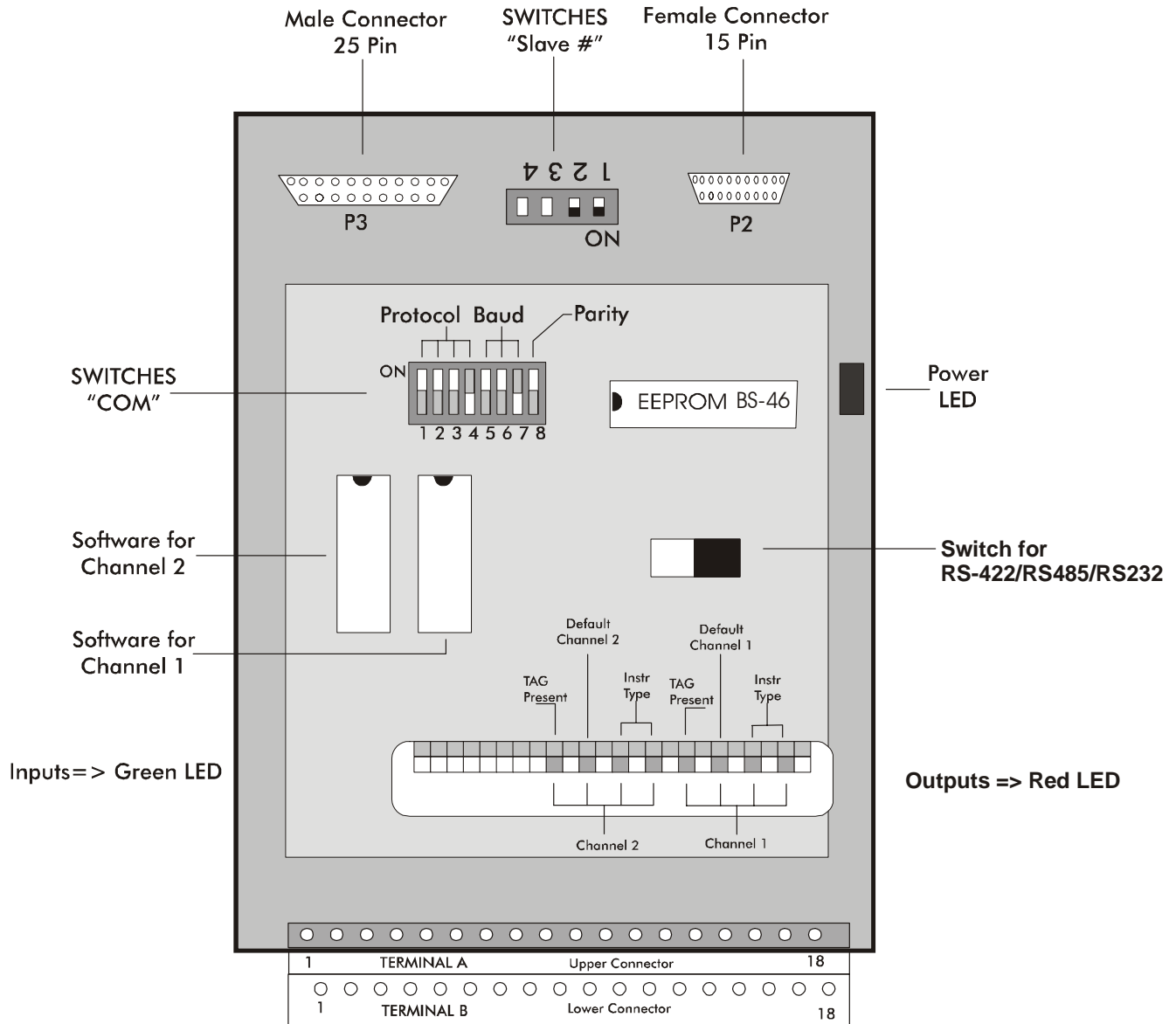

Configuration of the BS-46 Interface

Switches Slave #:

- Defines the slave number (which must be seen for each protocol).
- Not processed for 3964R Protocol and DF1 Protocol.
- If the slave number is defined for the RS-485 Connector, the 4 switches must be set to OFF.

OFF=0

ON=1

SW 1	SW 2	SW 3	SW 4	Slave
OFF	OFF	OFF	OFF	0
ON	OFF	OFF	OFF	1
OFF	ON	OFF	OFF	2
ON	ON	OFF	OFF	3
OFF	OFF	ON	OFF	4
ON	OFF	ON	OFF	5
OFF	ON	ON	OFF	6
ON	ON	ON	OFF	7
OFF	OFF	OFF	ON	8
ON	OFF	OFF	ON	9
OFF	ON	OFF	ON	10
ON	ON	OFF	ON	11
OFF	OFF	ON	ON	12
ON	OFF	ON	ON	13
OFF	ON	ON	ON	14
ON	ON	ON	ON	15

A.) Switches 1,2,3,4 = Protocol Configuration:

Protocol	SW1	SW2	SW3	SW4
UNITELWAY®	ON	OFF	OFF	OFF
3964R®	OFF	ON	OFF	OFF
MODBUS®/JBUS®	OFF	OFF	OFF	OFF
DF1®	OFF	OFF	ON	OFF
Allen Bradley Channel Zero DH+®				
SLC 503/504® OR PLC-5 Peer to Peer	ON	OFF	ON	OFF
PLC-5® OR SLC 503/504 Multi Drop	OFF	OFF	ON	OFF

The configuration (slave number, baud rate, parity, and protocol) is valid on power-up.

B.) Switches 5, 6, 7 = Baud Rate:

Baud Rate	SW5	SW6	SW7
19200	OFF	OFF	OFF
9600	ON	OFF	OFF
4800	OFF	ON	OFF
2400	ON	ON	OFF
1200	OFF	OFF	ON
600	ON	OFF	ON
300	OFF	ON	ON
150	ON	ON	ON

C.) Switch 8 = Parity:

Parity	SW8
ODD	OFF
EVEN	ON

For 3964R, the BS-46 DF1[®] and Full and Half duplex accept even parity only.

Note: If you change the BS-46 configuration, you must recycle power for the BS-46 to reflect the new configuration.

Electronic Characteristics

Power Supply:

- 24 VDC (< 2% ripple)*
- Power supply rating should include power for each Transceiver or R/W head.

Consumption Current:

- 70mA for BS-46 Control Board
- Each Transceiver requires an additional 150mA
- Forecast the current consumption for parallel I/O (if necessary)

Parallel Inputs:

- Impedance Z_e : 5K Ohms
- U max U_e : 55 Volts
- Level "0": 0 to 8 Volts
- Level "1": 18 V to + U (max power supply)

Note: The terminal B1 must be connected to 0 Volt.

Parallel Outputs:

- Maximum output current: 200mA
- Loss voltage (U_{sd}): 2 V
- Level "0": 50 μ A
- Level "1": U - U_{sd}
- Protected against load short-circuits

Note: The terminal A10 must be connected to the +U supply (see p. 9).

Serial Link RS-232:

- Output not connected: $U < -3$ Volts
- Level "0": $+3V < U < +12V$
- Level "1": $-12V < U < -3V$
- U max: $+ 24$ Volts

Serial Link RS-422:

- If not connected: output Y>Z

Opto-Electronic Isolation:

- Serial link
- Parallel I/O
- Transceiver links

Diagram of Parallel Inputs & Outputs

Parallel Inputs:

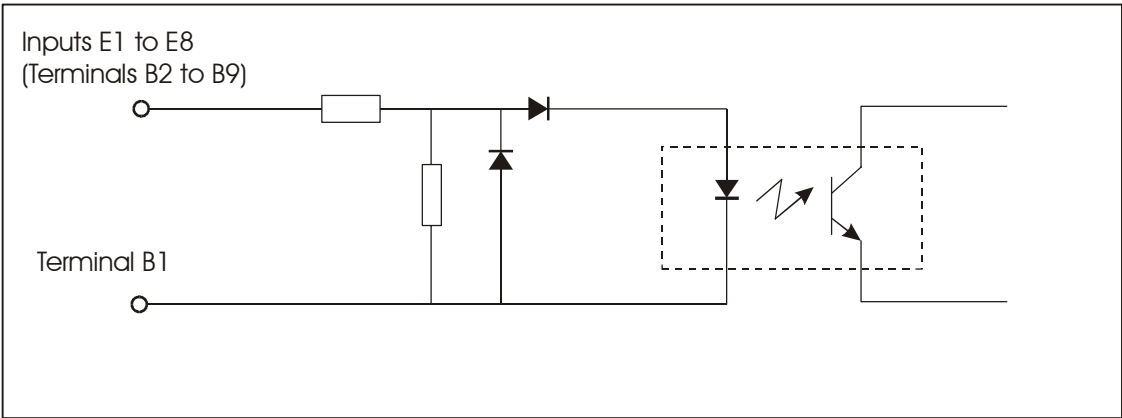

The // inputs are free of supply.
The terminal B1 must be connected to a 0 VDC (ex: terminal A1 = 0 VDC)

Parallel Outputs:

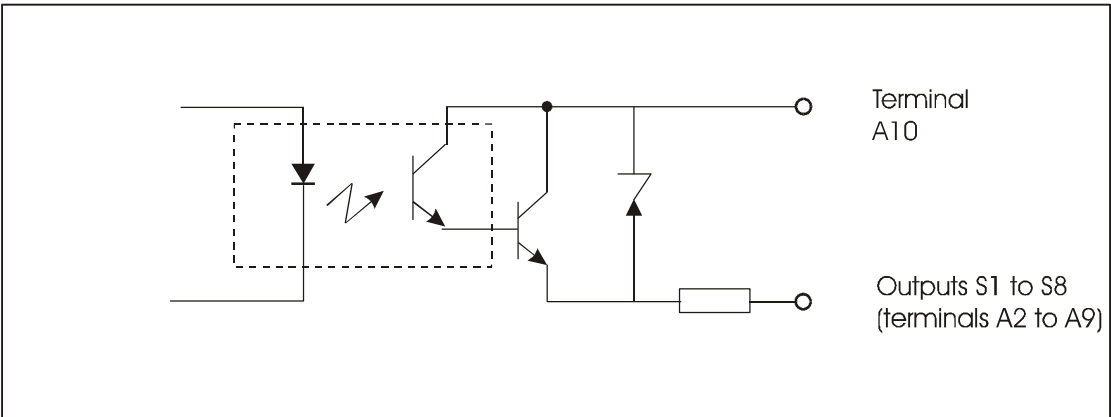

The // outputs are free of supply.
The terminal A10 must be connected to +24 VDC (ex: terminal B10 = +24 VDC).

Serial Link

The BS-46 offers 3 physical connections:

The red switch located internally on the right side of the BS-46 board allows you to disable the constant RS-232 serial link and enable your choice of either RS-422 or RS-485 serial links.

* Refer to the BS-46 diagram on page 4 for switch location.*

RS-422: Male connector 25 pins (P3)

Input: pin 24: Signal B = Rx-
pin 25: Signal A = Rx+

Output: pin 12: Signal Z = Tx- = (B)
pin 11: Signal Y = Tx+ = (A)

0 Volt: pin 13 must be connected to 0 Volts ground.

Note: Connection errors can damage the RS-422 link.

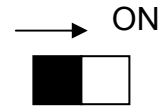

RS-232: Male connector 25 pins (P3)

Input: pin 3

Output: pin 2

0 Volt: pin 7

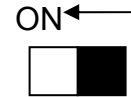

RS-485: Female connector 15 pins (P2)

Signal B: pin 14

Signal A: pin 7

0 Volt: pin 8/15

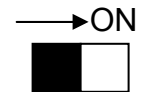

Note: When using the RS-485 link, the following pins on the 25 pin connector cable must be jumped from:

- pin 12 to 24
- pin 11 to 25

Left

No.	Low Terminal = B	No.	High Terminal = A
B1	Common Terminal for Inputs*	A1	0 Volt
B2	Input 1 = DCY11	A2	Output 1 = SURV
B3	Input 1 = DCY12	A3	Output 2 = ENR
B4	Input 1 = DCY13	A4	Output 3 = DEF
B5	Input 1 = DCY14	A5	Output 4 = PRE
B6	Input 1 = DCY21	A6	Output 5 = SURV
B7	Input 1 = DCY22	A7	Output 6 = ENR
B8	Input 1 = DCY23	A8	Output 7 = DEF2
B9	Input 1 = DCY24	A9	Output 8 = PRE2
B10	+ U Voltage *	A10	Common for Output
B11	+ U Power supply	A11	0 Volt Power Supply
B12		A12	0 Volt
B13	+ U Power Supply ->V or b1	A13	0 Volt ->0 or b4
B14	Input -> S or b2	A14	Output -> E or b3
B15		A15	0 Volt
B16	+ U Power Supply -V or b1	A16	0 Volt ->0 or b4
B17	Inputs -S or b2	A17	Output ->E or b3
B18	/	A18	/

Right

Note: When using the RS-485 link, the following pins on the 25 pin connector cable must be jumped from:

- pin 12 to 24
- pin 11 to 25

Connection

Parallel Inputs:

- Input DCY11 (DCY21) drives the 1st stored command ("CO" Mode) for Channel #1 (Channel #2).
- Input DCY12 (DCY22) drives the 2nd stored command ("CO" Mode) for Channel #1 (Channel #2).

Parallel Outputs:

- The output PRE indicates TAG presence, which is automatically controlled by the BS-46. It functions independently of any program being run.
- The output DEF indicates either a Transceiver fault or battery fault as indicated below:
 - PRE = 1 and DEF = 1 => battery fault
 - PRE = 0 and DEF = 1 => Transceiver fault
- The output SURV indicates the "AR" operation is executed.

Addressing of the BS-46 for Channel #1

Start Add*	End Add*	Designation	
0	1FFDH	TAG Addresses	
2000H	207FH	Buffer for "AR" Mode Command	
2080H	20FFH	Buffer for "CO" Mode Command	
2100H/		High Byte=0 or fault value in "DA" Mode, Low Byte=Image of the outputs	
2101H/		High Byte=0, Low Byte=Image of the inputs	
2180H	21FFH	Buffer 2 nd "CO" Mode Command	
2200H	227FH	Results Buffer for "AR" Mode	
2280H	22FFH	Results Buffer for "CO" Mode	
2300H	237FH	General Buffer, reading every result for the 2 Channels	
2380H	23FFH	Cumulative Buffer, reading the results for the 2 Channels	
3000H	307FH	History Buffer	Event 1 N
3080H	30FFH		Event 1 N-1
3100H	317FH		Event 1 N-2
3180H	31FFH		Event 1 N-3
3200H	327FH		Event 1 N-4
3280H	32FFH		Event 1 N-5
3300H	337FH		Event 1 N-6
3380H	33FFH		Event 1 N-7

* Word Addressing (16 bits):

If another address is read, the BS-46 gives the contents of the word 2100H
(1) results of commands realized under "AR" or "CO" Modes.

Note: The addressing of Channel #2 depends on the communication protocol used.

Use of the BS-46

The BS-46 offers 3 Access Modes:

1.) Direct Access Mode ("DA" Mode):

Allows a Read or Write directly to the TAG. This operation is composed of 3 steps:

- Order = TAG Read or Write request
- Action = TAG Reading or Writing
- Response = Results of action

2.) Automatic Read Mode ("AR" Mode):

This mode stores a TAG Read request, containing a maximum of 5 data zones. The TAG Read command will be executed as soon as the TAG arrives in zone. After the Results Buffer is read, the command will automatically read the next TAG (without a new PLC request). This allows easier and faster communication between a PLC and BS-46, and saves time.

The result can be automatically written into the PLC memory from an address defined in the command.

3.) Controlled Operating Mode ("CO" Mode):

This mode stores a command (TAG Read or Write), which will be executed every time a dedicated // input or an internal bit is activated. For each Channel, two independent commands can be stored. Each one controlled by a // input or an internal bit.

Example:

1.) TAG Reading at the work station	
- Identification of the product to be manufactured	=> "AR" Mode
- Data relating to the work to be performed	
- Data relating to the fabrication results	
2.) After the work is performed, results are written into the TAG	
- Command 1 = Write "everything's OK"	=> "CO" Mode
- Command 2 = Write "bad operation"	
3.) For other functions, Direct Access Mode can be used	=> "DA" Mode

Standard Operation of the BS-46

After the commands are written in the respective buffers, and if the results are not automatically sent (dependent on protocol), the results can be read in the dedicated Results Buffer for each Channel ("AR" or "CO" Mode Results Buffer).

The use of the General Buffer or the Cumulative Buffer offers the user other interesting possibilities.

Use of the General Buffer:

Addresses: 2300H to 23FFH

The General Buffer allows you to always read the same memory zone.

The General Buffer can contain every result concerning the 2 Channels (for "AR" or "CO" Mode).

If the result of the previous operation ("AR" or "CO" Mode) for one Channel is read, a new operation can be initiated on that Channel.

After reading, this result is stored in the History zone.

As long as the data in the General Buffer is not zero, the buffer can be read.

The BS-46 is able to retain the results of every executed event for each Channel and each Mode. If a result is read into another buffer, it cannot be read in the General Buffer anymore.

Use of the Cumulative Buffer:

Addresses: 2380H to 23FFH

The Cumulative Buffer allows you to obtain the "AR" Mode operation results for both Channels with only one request.

The results for Channel #1 and Channel #2 are stored consecutively in the Cumulative Buffer. If one of the two operations is not performed, the data of the respective zone is zero.

The user must always read all the words defined in the "AR" Mode Commands when using this buffer.

After the results are read, and if a new operation is required (TAG disappearance), the Results zone (Channel #1 or Channel #2) will be respectively reset.

The BS-46 processes the contents of the commands for Channel #1 and Channel #2. In case of an invalid command, the type message will be 7.

BS-46

Communications With
Allen Bradley PLC-5[®] Series,
Channel-Zero, using
Data-Highway Plus[®]
Message Instructions
“Multi Drop”

BALOGH

7699 Kensington Court
Brighton, MI 48116-8561
(248) 486-7343

Overview about the DF1® & DH+® Protocol

The BS-46 can be configured as a multi-drop serial interface slave unit, allowing communication with all styles of BALOGH'S electronic TAGS through Channel 0 on Allen Bradley's PLC-5®, using DH+® Typed Read and Typed Write Message Instructions via RS-422 serial connection. The BS-46 operates in three Modes: Direct Access (“DA”), Automatic Read (“AR”), and Controlled Operating (“CO”).

Hardware Configuration:

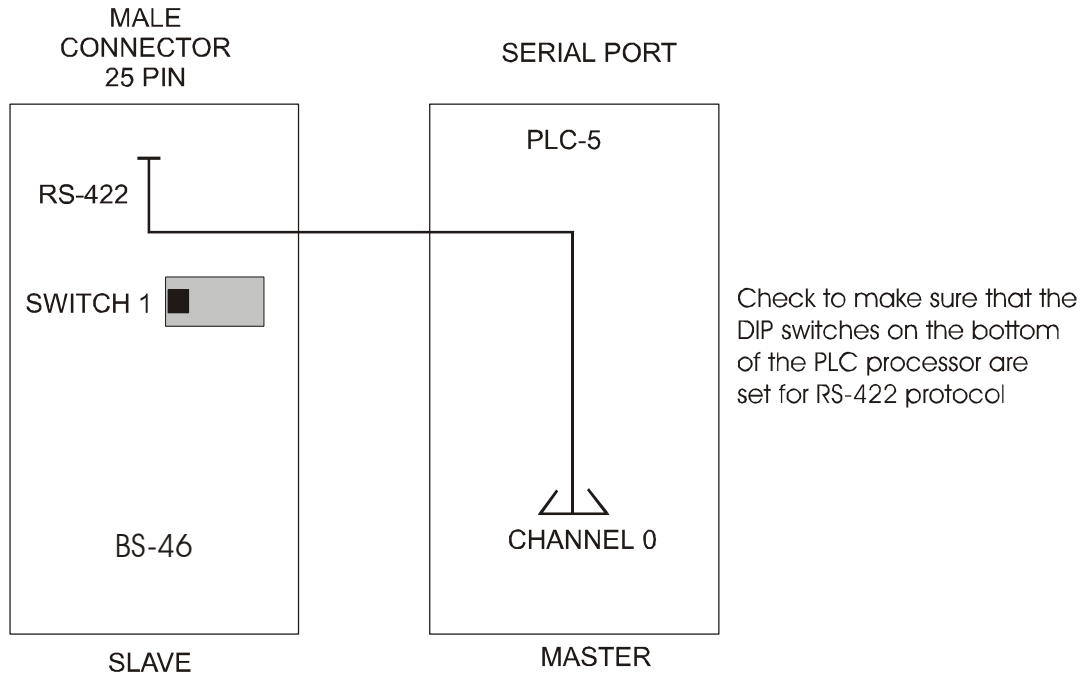

Pin Connections - RS-422 Connectors for Cable (100ft MAX)

BS-46 (Female 25 Pin)	PLC-5 (Male 25 Pin)
Pin 11 Tx+(y)	Pin 16 Rx+(y)
Pin 12 Tx-(z)	Pin 3 Rx-(z)
Pin 24 Rx-(B)	Pin 2 Tx-(B)
Pin 25 Rx+(A)	Pin 14 Tx+(A)
Pin 13 0 Volt	Pin 7 0 Volt

Protocol DIP Switch Settings:

Protocol	SW1	SW2	SW3	SW4
DH+ CH0	OFF	OFF	ON	OFF

Note: Check to make sure that the DIP switches on the bottom of the PLC processor are configured for RS-422 protocol.

Software Configuration

The software configuration text and screen captures are based on the Allen Bradley 6200 Series Software Product Release 4.5®

To configure the Software for the BS-46 to Channel 0 of the PLC-5®, complete the following steps:

1. Go to the processor program directory (ladder logic screen).
2. Select the <F7> General Utility.
3. Select <F4> Channel Overview.
4. Select Convert Channel 0 to System (Master) as shown below.

The screenshot shows the 'Edit Channel Properties' dialog box for Channel 0. The 'Communication Mode' section has 'System (Master)' selected. The 'Serial Port' section shows Baud Rate: 19.2K, Parity: Even, Bits Per Char: 8, Stop Bits: 1, and Control Line: No Handshaking. The 'Remote Mode Change' section has 'Enable' checked, Attention Char: \0x1b, System: S, and User: U. The 'Diagnostic File' is set to 0. Buttons for OK, Cancel, Apply, and Help are at the bottom.

5. Choose <F5> Channel Configure. It will allow you to designate the baud rate, stop bits, and parity according to the DIP switch selection on the BS-46.
6. Set the Polling Mode to **Standard**
(Multiple Message Transfer Per Node Scan)

Below is an example of how the configuration may look. A normal Poll Node File must be chosen and configured.

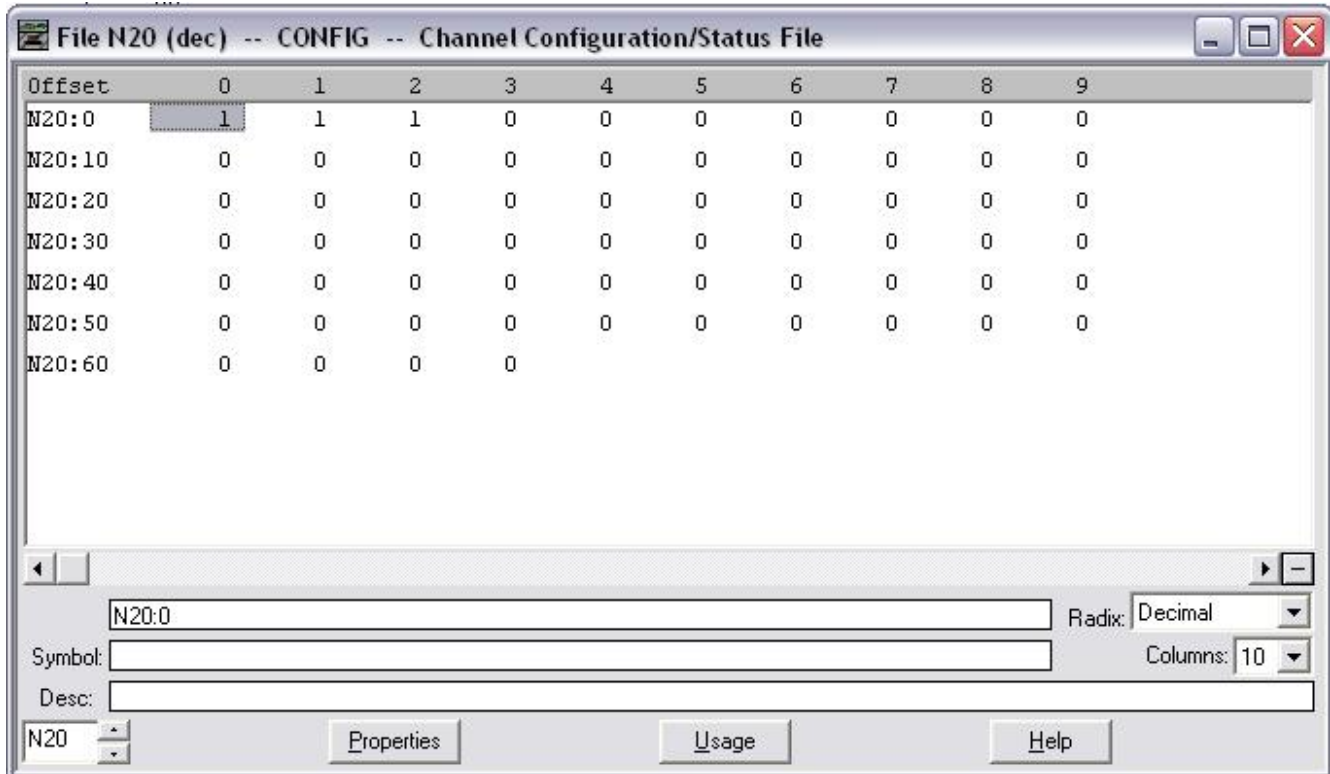

Polling Table

Information for each BS-46 on the link must be entered in the Polling Data Table (normal Poll Node File). In the following example, integer file N20 is a user defined integer file chosen from the Channel Configuration menu. The address N20:0 refers to the number of BS-46 units on the RS-422 serial link. In the example below, four BS-46 units are multi-dropped from the RS-422 serial link to Channel 0. The next location, N20: 1, is automatically updated by the PLC-5[®] (it is an automatic value, not a user defined value). Locations N20: 2 to N20: 5 are the individual slave numbers of the BS-46's to be polled. This is done in priority sequence starting with N20: 2. The maximum number of BS-46's to be polled is 16 corresponding to the BS-46's slave number's 0-15 on the Node.

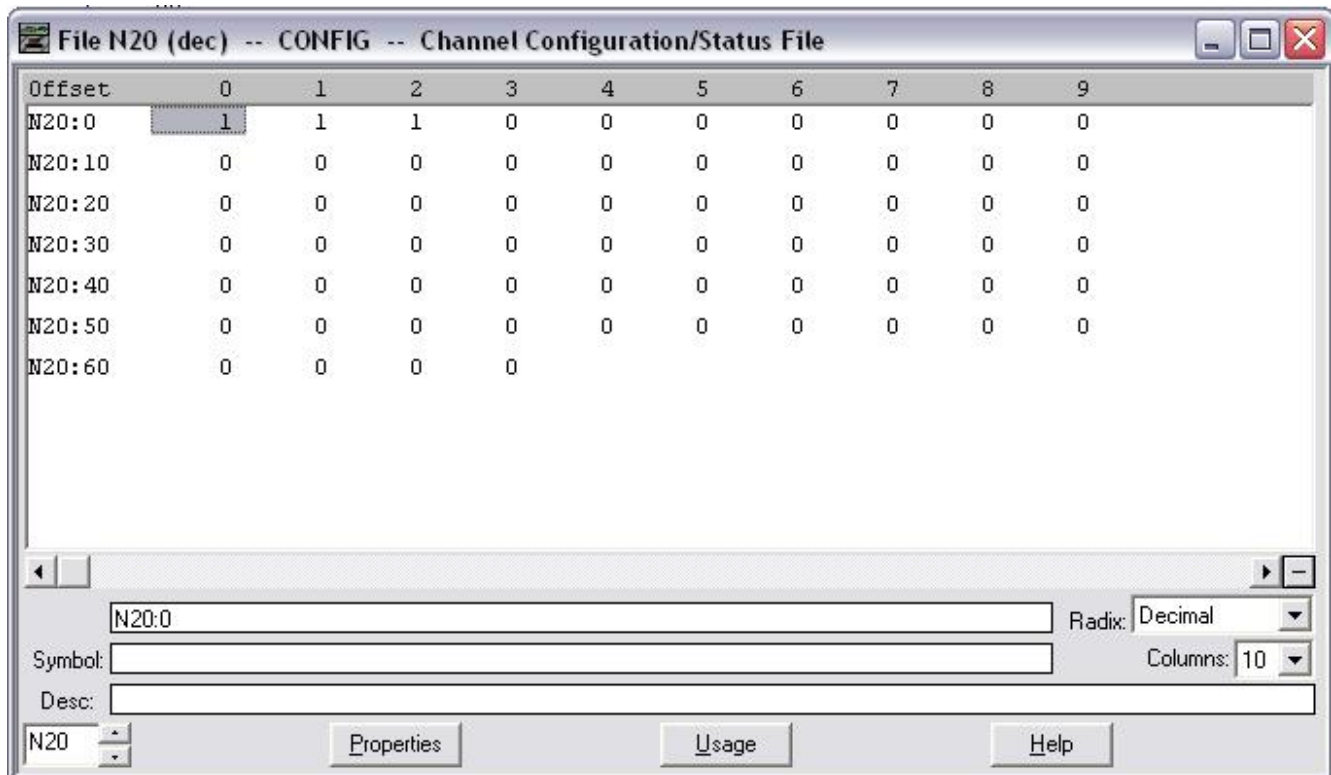

The screenshot shows a software window titled "File N20 (dec) -- CONFIG -- Channel Configuration/Status File". It contains a table with 11 columns labeled "Offset" (0-9) and 7 rows of data. The data is as follows:

Offset	0	1	2	3	4	5	6	7	8	9
N20:0	1	1	1	0	0	0	0	0	0	0
N20:10	0	0	0	0	0	0	0	0	0	0
N20:20	0	0	0	0	0	0	0	0	0	0
N20:30	0	0	0	0	0	0	0	0	0	0
N20:40	0	0	0	0	0	0	0	0	0	0
N20:50	0	0	0	0	0	0	0	0	0	0
N20:60	0	0	0	0						

Below the table, there are input fields for "N20:0", "Symbol:", and "Desc:". The "N20:0" field contains "N20:0", "Radix" is set to "Decimal", and "Columns" is set to "10". At the bottom, there are buttons for "N20", "Properties", "Usage", and "Help".

- NXX:00 - Total number of BS-46's on RS-422 link (16 Max.)
- NXX:01 - PLC-5[®] automatically updates the next location
- NXX:02 - Number for first BS-46 (0 - 15)
- NXX:YY - Number for last BS-46 (0 - 15)

Note: The PLC Node ID must be set to a different Node ID than the Node ID of the BS-46. If the PLC and the BS-46 are both configured to the same Node ID, the system will experience communication difficulties.

BS-46 Addressing

Table 1 and Table 2 list the buffer address locations in decimal for the BS-46, as the PLC uses integer values to communicate with the BS-46.

TABLE 1. Transceiver Channel #1:

Designation	Start Address	Stop Address
Buffer for "AR" Mode Command	N144:00	N144:127
Buffer for "CO" Mode Command	N144:128	N144:255
High Byte = 0 or fault value in "DA" Mode Low Byte = image of the outputs	N144:256	-----
High Byte = 0 Low Byte = image of inputs	N144:257	-----
Buffer 2nd "CO" Mode Command	N144:384	N144:509
Results Buffer for "AR" Mode	N145:00	N145:127
Results Buffer for "CO" Mode	N145:128	N145:255
General Buffer giving back every result for both Channels	N145:256	N145:383
Cumul Buffer giving back results for both Channels	N145:384	N145:509
Historic Buffer event (1)	N152:0	N152:127
Historic Buffer event (2)	N152:128	N152:255
Historic Buffer event (3)	N152:256	N152:383
Historic Buffer event (4)	N152:384	N152:509
Historic Buffer event (5)	N153:0	N153:127
Historic Buffer event (6)	N153:128	N153:255
Historic Buffer event (7)	N153:256	N153:383
Historic Buffer event (8)	N153:384	N153:509

TABLE 2. Transceiver Channel #2:

Designation	Start Address	Stop Address
Buffer for "AR" Mode Command	N208:00	N208:127
Buffer for "CO" Mode Command	N208:128	N208:255
High Byte = 0 or fault value in "DA" Mode Low Byte = image of the outputs	N208:256	-----
High Byte = 0 Low Byte = image of the inputs	N208:257	-----
Buffer 2nd "CO" Mode Command	N208:384	N208:509
Result Buffer for "AR" Mode	N209:00	N209:127
Results Buffer for "CO" Mode	N209:128	N209:255
General Buffer giving back every result for both Channels	N209:256	N209:383
Cumul Buffer giving back results for both Channels	N209:384	N209:509
Historic Buffer event (1)	N216:0	N216:127
Historic Buffer event (2)	N216:128	N216:255
Historic Buffer event (3)	N216:256	N216:383
Historic Buffer event (4)	N216:384	N216:509
Historic Buffer event (5)	N217:0	N217:127
Historic Buffer event (6)	N217:128	N217:255
Historic Buffer event (7)	N217:256	N217:383
Historic Buffer event (8)	N217:384	N217:509

Direct Access Mode (“DA” Mode)

Direct Access Mode (“DA”) is used to read data from a TAG with a **Typed Read** message directly into the PLC-5[®] Data Table. The “DA” Mode can also be used to write data directly from the PLC-5[®] Data Table to a TAG with a **Typed Write** Message Instruction. In the Direct Access Mode, the BS-46 acts as a pass through device for the command. It holds no program within its own memory.

Note: During a “DA” Mode operation, the TAG must be present, or a time out error will occur in the Message Instruction. This will cause a communications fault in the BS-46's “DA” Mode Fault Buffer and give a Message Instruction error in the PLC software.

The following table describes the mapping of the TAG memory. The address ranges shown are used as Data File Addresses when Reading or Writing the TAG in the Direct Access Mode.

“DA” Mode PLC-5[®] OMA 64 Byte Addressing:

“OMA” 64 byte Channel #1	Memory Range (In bytes)	“OMA” 64 byte Channel #2
N130:00 - N130:31	0 - 64	N194:00 - N194:31

“DA” Mode PLC-5[®] OMA 2K Addressing:

“OMA” 2K TAG Channel #1	Memory Size (In bytes)	“OMA” 2K TAG Channel #2
N128:0 - N128:511	0 - 1024	N192:0 - N192:511
N129:0 - N129:509	1025 - 2048	N193:0 - N193:509

“DA” Mode PLC-5[®] with OMA 8K TAG Addressing:

“OMA” 8K TAG Channel #1	Memory Range (In bytes)	“OMA” 8K TAG Channel #2
N136:0 - N136:511	0 - 1024	N200:0 - N200:511
N137:0 - N137:511	1025 - 2048	N201:0 - N201:511
N138:0 - N138:511	2049 - 3072	N202:0 - N202:511
N139:0 - N139:511	3073 - 4096	N203:0 - N203:511
N140:0 - N140:511	4097 - 5120	N204:0 - N204:511
N141:0 - N141:511	5121 - 6144	N205:0 - N205:511
N142:0 - N142:511	6145 - 7168	N206:0 - N206:511
N143:0 - N143:509	7169 - 8188	N207:0 - N207:509

"DA" Mode PLC-5[®] with OMX 8K TAG Addressing:

"OMX" 8K TAG Channel #1	Memory Range (In bytes)	"OMX" 8K TAG Channel #2
N128:0 - N128:511	0 - 1024	N192:0 - N192:511
N129:0 - N129:511	1025 - 2048	N193:0 - N193:511
N130:0 - N130:511	2049 - 3072	N194:0 - N194:511
N131:0 - N131:511	3073 - 4096	N195:0 - N195:511
N132:0 - N132:511	4097 - 5120	N196:0 - N196:511
N133:0 - N133:511	5121 - 6144	N197:0 - N197:511
N134:0 - N134:511	6145 - 7168	N198:0 - N198:511
N135:0 - N135:509	7169 - 8188	N199:0 - N199:509

"DA" Mode PLC-5[®] OF 7 Byte Read-Only TAG:

"OF" Read-Only TAG Channel #1	Memory Range (In bytes)	"OF" Read-Only TAG Channel #2
N128:00 - N128:3	0-6	N192:00 - N192:3

Reading a TAG in "DA" Mode

A Typed Read Message Instruction is used to read data from a TAG directly to a PLC Data Table Address.

The setup is as follows:

1. The PLC-5[®] Data Table Address is where the data read from the TAG appears after a Read complete operation.
2. The Size in Elements is the number of words (each word is 2 bytes) that is read from the TAG.
3. The Destination Data Table Address is the starting TAG address and Channel Number designation to begin reading.
4. The Local Node Address is the slave number location of the BS-46 to receive the command (set by the DIP switch at the top of BS-46).
Note: This address is octal format, for example, BS-46 #15 would be 17 Octal.
5. The Port Number is **Zero** for Channel 0.

The **Typed Read** Message Instruction in the example below displays a direct read of 10 words (20 bytes) starting at N194:0 (Transceiver Channel #2 and OMA-64 byte TAG address beginning with the first byte of the TAG) of BS-46 Node ID #2. The TAG data will be read into the PLC-5[®] and stored beginning in Data Table Address N7:60.

The screenshot shows a software window titled "MSG - Rung #2:3 - MG9:0" with a "General" tab selected. The configuration is as follows:

- This PLC-5:**
 - Communication Command:
 - Data Table Address:
 - Size in Elements:
 - Port Number:
- Target Device:**
 - Data Table Address:
 - Local Station Address (oct): (dec):
 - Local / Remote:
- Control Bits:**
 - Ignore if timed out (TO):
 - To be retried (NR):
 - Awaiting Execution (EW):
 - Continuous Run (CO):
 - Error (ER):
 - Message done (DN):
 - Message Transmitting (ST):
 - Message Enabled (EN):
- Error:**
 - Error Code(Hex): 92
- Error Description:**
 - no response (regardless of station type)

Writing to a TAG in "DA" Mode

Typed Write Message Instructions are used to write data directly from the PLC Data Table to a TAG.

The setup is as follows:

1. The PLC-5[®] Data Table Address is where the data written to the TAG is entered.
2. The Size in Elements is the number of words (each word is 2 bytes) written to the TAG.
3. The Destination Data Table Address is the starting TAG address and the Channel Number designation to begin writing the data to.
4. The Local Node Address is the slave number of the BS-46 (set by DIP switch at the top of the BS-46) to receive the command.
Note: This address is octal format, for example, BS-46 #15 would be 17 octal.
5. The Port Number is **Zero** for Channel 0.

The example below displays a **Type Write** Message Instruction for a direct write of 10 words (20 bytes) from PLC-5[®] Data Table Address N7:40 to TAG address N194:0 on Transceiver Channel #2 of BS-46 number 2.

The screenshot shows a software window titled "MSG - Rung #2:6 - MG9:2" with a "General" tab. The configuration is as follows:

- This PLC-5:**
 - Communication Command: PLC-5 Typed Write
 - Data Table Address: N7:40
 - Size in Elements: 10
 - Port Number: 0
- Target Device:**
 - Data Table Address: N194:0
 - Local Station Address (oct): 2 (dec): 2
 - Local / Remote: Local
- Control Bits:**
 - Ignore if timed out (TO): 0
 - To be retried (NR): 0
 - Awaiting Execution (EW): 0
 - Continuous Run (CO): 0
 - Error (ER): 0
 - Message done (DN): 0
 - Message Transmitting (ST): 0
 - Message Enabled (EN): 0
- Error:**
 - Error Code(Hex): 92
- Error Description:**
 - no response (regardless of station type)

Fault Condition in "DA" Mode

When Direct Access Mode is executed and a fault occurs in the Message Instruction, besides getting the error code for the Message Instruction, the status register (N144:256 for Channel #1 or N208:256 for Channel #2) of the BS-46 can be read to detect the fault condition. Below is a list of the Status Addresses and the BS-46 Fault Codes.

Fault Locations "DA" Mode:

Channel Number	BS-46 Address
Transceiver 1	N144:256
Transceiver 2	N208:256

Fault Codes:

Fault Code "DA" Mode	Description
9BH	Invalid address for TAG type
9CH	Fault with Transceiver or Transceiver linking
9EH	Invalid data in the TAG
9FH	Dialogue impossible to complete

Note: Data returned from a TAG Read function is a "first read-first in" scheme. This means the **First byte** read will appear in the first word's **High byte** in the PLC Data Table. The **Second byte** read will appear in the first word's **Low byte** in the PLC Data Table.

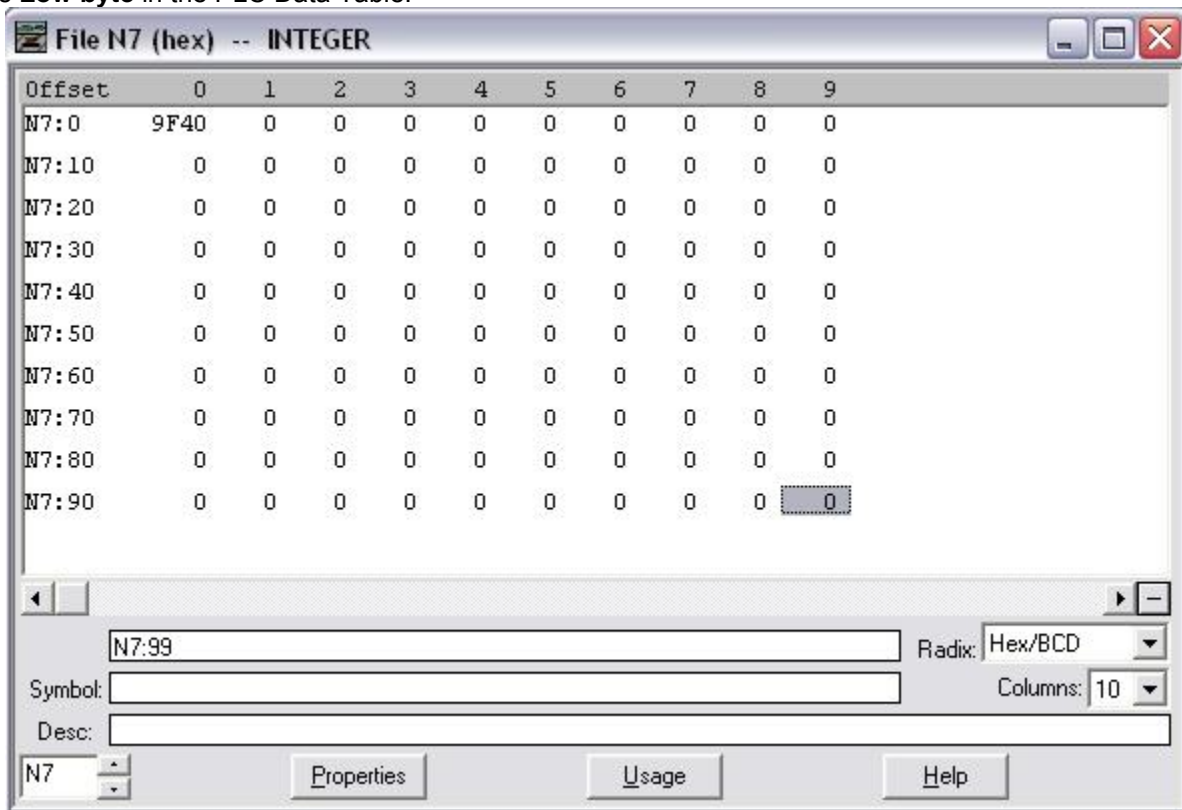

Automatic Reading Mode (“AR” Mode)

This mode executes the automatic reading of a TAG as it enters the designated Transceiver zone. Up to 5 memory zones can be read from the TAG in a single read operation. A **Typed Write** Message Instruction is used to program the BS-46 to execute "AR" Mode. The **Typed Read** Message Instruction is used to read the "AR" Results Buffer to transfer the data read by the BS-46 from the TAG to the PLC Data Table, after a TAG Read occurs.

Addressing "AR" Mode:

Channel Number	Transceiver 1	Transceiver 2
Command Buffer	N144:00 - N144:127	N208:00 - N208:127
Results Buffer	N145:00 - N145:127	N209:00 - N209:127

Command Code “AR” Mode:

Word 1	Command Word
Word 2	Number of words to Read in Zone 1
Word 3	TAG address of Zone 1 to begin Reading
Word 4 (optional)	Number of words to Read in Zone 2
Word 5 (optional)	TAG address of Zone 2 to begin Reading
Word 10 (optional)	Number of words to Read in Zone 5
Word 11 (optional)	TAG address of Zone 5 to begin Reading

Word 1

(Value 2 or 3)

The first word of data in the PLC-5[®] Data Table Address is the **Command Word**.

If the Command Word 1 = 2, instructs a one time Read with wait.

If the Command Word 1 = 3, instructs repeated Reads with wait.

Word 2

(“AR”) Command Code

The second word in the PLC-5[®] Data Table Address is the length in words (each word equals 2 bytes) to be read from the TAG with a maximum of 62 words (124 bytes). The "AR" Buffer is 64 words (128 bytes) with 2 words (4 bytes) reserved for status.

Word 3

The third word in the PLC-5® Data Table Address is the TAG address, which begins the zone read. See table below:

TAG	Memory Availability	Memory Mode	Addressing (In bytes)
OF	7 bytes	Factory Programmed	0 to 6
OFR	7 bytes	User Re-Programmable	0 to 6
OMA	64 bytes	Ferro-Electric	2048 to 2112
	2K bytes		0 to 2047
	8K bytes		0 to 8180
OMX	8K bytes	Ferro-Electric	0 to 8180
	32K bytes		0 to 32767
GIE	512 bytes	Ferro-Electric	0 to 511
	2K bytes		0 to 2047
	8K bytes		0 to 8180
OIR	32K bytes	Ferro-Electric	0 to 32767
OP*	64 bytes	EEPROM	0 to 63 (Read)
			12 to 75 (Write)
OL	2 bytes	Factory Programmed	0 to 1
OLR	2 bytes	User Re-Programmable	0 to 1

* Note: Must Read/Write in blocks of (4) bytes to OP TAG

These 3 words complete one "AR" Mode zone to be read in the TAG.

Note: There can be up to 5 zones.

- All five zones combined must not occupy more than 62 words (124 bytes) on a single read.
- Using more than one zone relates to discontinuous block reads.

The example below displays an "AR" Command Code string, starting at N7:0, with repeated reads of 10 words (20 bytes) of external memory of a TAG beginning at TAG addresses 0, 20, 40, 60 and 80. This occurs each time a TAG enters the Transceiver zone. This "AR" Command Code string uses all 5 zones.

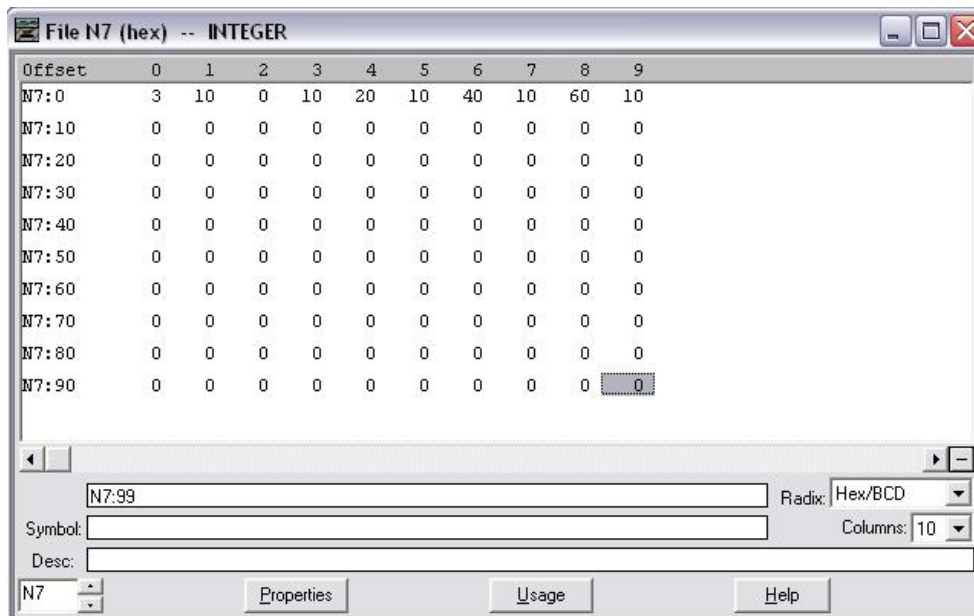

Writing to the "AR" Mode Buffer

The Typed Write Message Instruction is used to write the "AR" Command Code to the BS-46's "AR" Command Buffer:

1. The Data Table Address is where the "AR" Command Code string is entered in the PLC.
2. The Destination Data Table Address is the address of the "AR" Command Buffer in the BS-46 where the Command Code is written to.
3. The Size in Elements is the length in words of the "AR" Command Code. It is dependent on the number of zones used. One command set zone occupies three word elements (two words additional for each extra zone). The maximum Size of Elements is 11 words using all five zones and a minimum of 3 words using just one zone.
4. The Local Node Address is the slave number of BS-46 (Node ID) to receive the command.
Note: This address is octal, for example, BS-46 #15 would be 17 octal.
5. The Port Number is **Zero** for Channel 0.

The example below displays a Typed Write Message Instruction that writes a "command string" of 11 elements, stored at PLC Data Table Address N7:0 to address N144:0, which is the "AR" Channel #1 Command Buffer of BS-46 number Node ID #3.

Note: The BS-46 needs to be programmed only once, even if programmed for repeated reads. However, it must be reprogrammed if power is recycled.

The screenshot shows a software window titled "MSG - Rung #2:6 - MG9:2" with a "General" tab. The configuration is as follows:

- This PLC-5:**
 - Communication Command: PLC-5 Typed Write
 - Data Table Address: N7:0
 - Size in Elements: 11
 - Port Number: 0
- Target Device:**
 - Data Table Address: N144:0
 - Local Station Address (oct): 3 (dec): 3
 - Local / Remote: Local
- Control Bits:**
 - Ignore if timed out (TO): 0
 - To be retried (NR): 0
 - Awaiting Execution (EW): 0
 - Continuous Run (CO): 0
 - Error (ER): 0
 - Message done (DN): 0
 - Message Transmitting (ST): 0
 - Message Enabled (EN): 0
- Error:**
 - Error Code(Hex): 92
- Error Description:**
 - no response (regardless of station type)

Reading the "AR" Mode Buffer

The Typed Read Message Instruction is used to read the data into the PLC Data Table from the BS-46 ("AR") Results Buffer:

1. The Data Table Address is where the "AR" results will be stored in the PLC.
2. The Destination Data Table Address is the address and Channel Number of the "AR" Results Buffer to read the information from.
3. The Local Node Address is the slave address of the BS-46 to receive the command.

Note: This address is octal, for example, BS-46 #15 would be 17 octal.

4. The Port Number is **Zero** for Channel 0.
5. The Size in Elements is the number of words read back from the ("AR") Results Buffer.

Note: The size in elements must be greater by 2 than the number of words read from the TAG to account for 2 words of status. Otherwise, the BS-46 will not be reset to do another Automatic Read.

The example below displays a Typed Read Message Instruction that will read 52 words (104 bytes) from the Channel #1 "AR" Results Buffer of BS-46 Node ID #3 to the PLC Data Table Address N7:20.

The screenshot shows a software window titled "MSG - Rung #2:3 - MG9:0" with a "General" tab. The configuration is as follows:

- This PLC-5**
 - Communication Command:
 - Data Table Address:
 - Size in Elements:
 - Port Number:
- Target Device**
 - Data Table Address:
 - Local Station Address (oct): (dec):
 - Local / Remote:
- Control Bits**
 - Ignore if timed out (TO):
 - To be retried (NR):
 - Awaiting Execution (EW):
 - Continuous Run (CO):
 - Error (ER):
 - Message done (DN):
 - Message Transmitting (ST):
 - Message Enabled (EN):
- Error**
 - Error Code(Hex):
- Error Description**
 - no response (regardless of station type)

Contents of Results Buffer in "AR" Mode

- Word 1** High Byte = message type (value 1 for Channel #1 or value 2 for Channel #2), single and multiple reads.
Low Byte = Event counter per message type.
- Word 2** If High Byte = 0 then the message is correct. If it is not equal to zero, then the Fault Code is contained in Low Byte (see chart on page 35).
- Word 3++** Begins the data Read from the TAG.

The example below displays the "AR" Mode Results Buffer starting at PLC Data Table Address N7:20. The first 2 words are status words. The High Byte of N7:20 (01H) stands for Channel #1. The Low Byte of N7:20 (03H) is the third event from which the "AR" Mode Results Buffer has read since the "AR" Mode was programmed into the BS-46. The value of 00H in 7:21 means there was not an error in the event. The data from address N7:21 to N7:71 is the data read from the TAG in the specified zones listed in the "AR" Command Code string example. The 1's came from TAG Zone 1, 2's TAG Zone 2, 3's TAG Zone 3, 4's TAG Zone 4, and 5's TAG Zone 5.

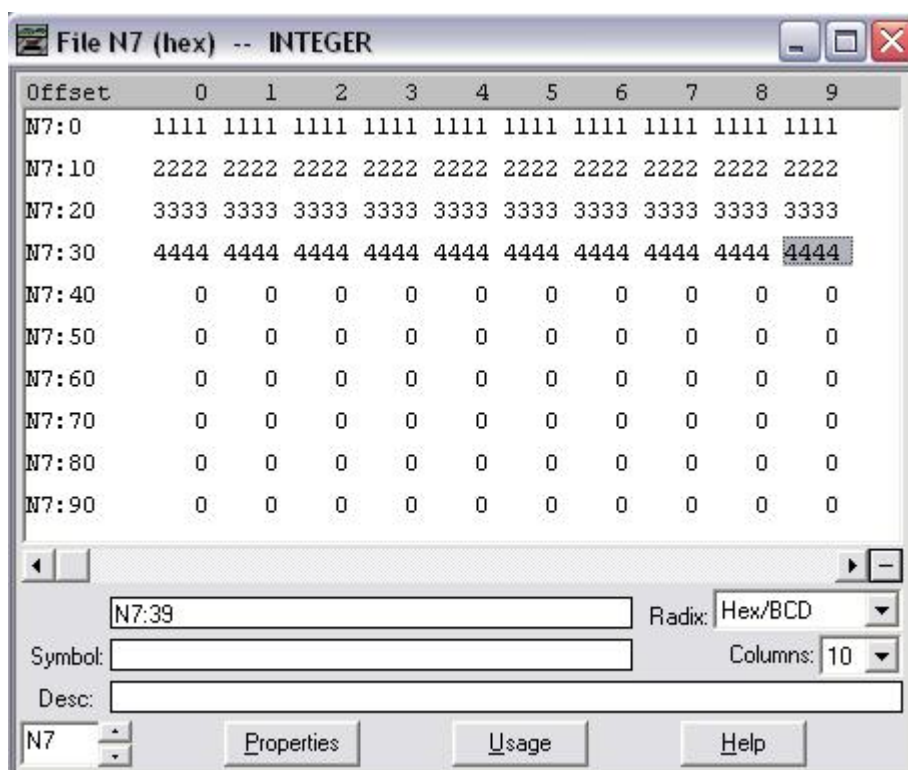

Faults "AR" Mode

Low Byte of Word 2 from "AR" Results Buffer:

Fault Code "AR" Mode	Description
9FH	Dialogue impossible to complete
9CH	Transceiver fault
9EH	Invalid data in TAG
9BH	Addressing error
90H	Configuration error

Operation of "AR" Mode:

BS-46 is programmed for "AR" Mode to do repeated Reads.

TAG enters the Transceiver zone, or was already in zone at the time when "AR" Mode was issued. The TAG is read, and the BS-46 sets the SURV output for that Channel high when complete.

Channel Number	Output
Transceiver 1	A2 - SURV1
Transceiver 2	A6 - SURV2

1. Condition 1: TAG still present and the "AR" Results Buffer is read.

Results 1: The "AR" Mode will not be reset to do another Read until the TAG leaves the Transceiver zone. Once the TAG leaves the zone, the SURV output drops low and the "AR" Mode is reset to do another Read.

2. Condition 2: TAG leaves Transceiver zone before the "AR" Results Buffer is read.

Results 2: Once the "AR" Results Buffer is read, "AR" Mode is reset to do another TAG Read.

3. Condition 3: TAG leaves the Transceiver zone before the "AR" Results Buffer is read and another TAG enters the zone.

Results 3: Once the "AR" Results Buffer is read, the "AR" Mode will be Reset, and the TAG in zone will automatically be read.

Note: When the "AR" Mode is reset, the previous read data is stored in the Historic Buffer. The BS-46 can be reset by reading the Results Buffer, the Cumul Buffer, or the General Buffer. Once the "AR" Mode is reactivated, the Results Buffer is reset to zero.

Controlled Operating Mode (“CO” Mode)

This mode executes a command stored in the "CO" Mode Command Buffer when a parallel input is set, or by a serial link instruction. The results are stored in the "CO" Mode Results Buffer. The Typed Write Message Instruction is used to write the Command Code to the BS-46. The Typed Read Message Instruction is used to read back the results once the operation is complete. Two Command Codes can be stored for each Channel.

Note: The BS-46 must be reprogrammed when power is cycled.

Addressing "CO" Mode:

Channel	Addressing
Transceiver 1 Command 1	N144:128 - N144:255
Transceiver 1 Command 2	N144:384 - N144:509
Transceiver 2 Command 1	N208:128 - N208:255
Transceiver 2 Command 2	N208:384 - N208:509
Transceiver 1 Results Buffer	N145:128 - N145:255
Transceiver 2 Results Buffer	N209:128 - N209:255

Command Code "CO" Mode:

Command Code (“CO”) Mode	Description
Word 1	Command Word
Word 2	Function
Word 3	Quantity in words to be Read or Written
Word 4	TAG address to begin the Read or Write
Word 5++	(Data if a Write request)

Word 1 = Command Word (values 1 or 2)

If the value = 1, then command executes when corresponding input is set high. This command will stay in the BS-46 and will not need to be reset unless power is recycled.

Input (Terminal B2) triggers Command 1 for Channel #1

Input (Terminal B3) triggers Command 2 for Channel #1

Input (Terminal B6) triggers Command 1 for Channel #2

Input (Terminal B7) triggers Command 2 for Channel #2

If the value = 2, then command executes immediately after the message is sent by the serial link and must be reset after each performance.

Word 2 = Function (values 0, 1, 2, 3)

If value is 0 = TAG Reading without wait.

If value is 1 = TAG Writing without wait.

If value is 2 = TAG Reading with wait.

If value is 3 = TAG Writing with wait.

Word 3 = Quantity in words to be Read or Written

62 words is the maximum for a Read command.
60 words is the maximum for a Write command.

- The "CO" Mode Results Buffer is 64 words with two words reserved for status, which reduces the Read to 62 words.
- The "CO" Mode Command Buffer is 64 words with 4 words reserved for the "CO" Command Code, which reduces the Write to 60 words.

Word 4 = Address of TAG "CO" Command Code

TAG Addresses "CO" Mode:

TAG	Memory Availability	Memory Mode	Addressing (In bytes)
OF	7 bytes	Factory Programmed	0 to 6
OFR	7 bytes	User Re-Programmable	0 to 6
OMA	64 bytes	Ferro-Electric	2048 to 2112
	2K bytes		0 to 2047
	8K bytes		0 to 8180
OMX	8K bytes	Ferro-Electric	0 to 8180
	32K bytes		0 to 32767
GIE	512 bytes	Ferro-Electric	0 to 511
	2K bytes		0 to 2047
	8K bytes		0 to 8180
OIR	32K bytes	Ferro-Electric	0 to 32767
OP*	64 bytes	EEPROM	0 to 63 (Read)
			12 to 75 (Write)
OL	2 bytes	Factory Programmed	0 to 1
OLR	2 bytes	User Re-Programmable	0 to 1

* Note: Must Read/Write in blocks of (4) bytes to OP TAG

Word 5++ = Data if command is a Write request.

The example below displays a "CO" Command Code string, beginning at N9:0, to do a **Write TAG with Wait** sent to the BS-46 through the RS-422 serial link. The quantity of words written to the TAG is 20 (40 bytes or 14H), starting at the external memory of TAG address 5. The data written to the TAG is 01H for every byte.

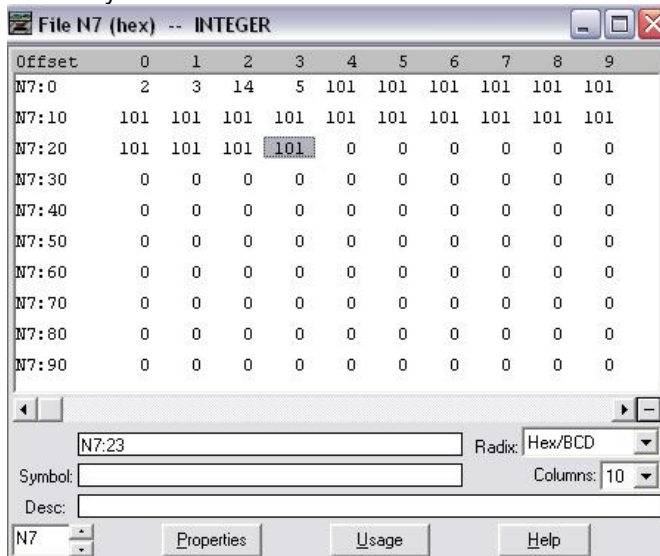

Writing to the "CO" Mode Buffer

A Typed Write Message Instruction is used to write the "CO" Command Code to the BS-46's "CO" Command Buffer:

1. The Data Table Address is where the "CO" Mode Command Code string is entered in the PLC.
2. Size in Elements is the length in words of the "CO" Mode Command Code string.
3. The Destination Data Table Address is the "CO" Mode Command buffer address to where the Command Code is sent.
4. The Local Node Address is the slave number (Node ID) of the BS-46 to receive the command.

Note: This address is octal format, for example, BS-46 #15 would be 17 octal.

5. The Port Number is **Zero** for Channel 0.

The example below displays a Typed Write Message Instruction which writes 24 words from PLC-5[®] Data Table Addresses N9:0 to N144:128, which is the address of Channel #1 "CO" Command 1 Buffer for BS-46 ID #3. The 24 words include the "CO" Command Code from the previous "CO" example and the data to write to the TAG.

MSG - Rung #2:6 - MG9:2

General

This PLC-5

Communication Command: PLC-5 Typed Write

Data Table Address: N9:0

Size in Elements: 24

Port Number: 0

Control Bits

Ignore if timed out (TO): 0

To be retried (NR): 0

Awaiting Execution (EW): 0

Continuous Run (CO): 0

Error (ER): 0

Message done (DN): 0

Message Transmitting (ST): 0

Message Enabled (EN): 0

Error

Error Code(Hex): 92

Error Description

no response (regardless of station type)

Reading from the "CO" Mode Buffer

The Typed Read Message Instruction is used to read the "CO" Mode Results Buffer into the PLC Data Table:

1. The Data Table Address is where the "CO" results are stored in the PLC.
2. The Size in Elements is the length in words that are in the "CO" Results Buffer. The Size of Elements has to be 2 words greater than the number of words that was read or written to the TAG.
3. The Destination Data Table Address is the "CO" Mode Results buffer address where the command is sent.
4. The Local Node Address is the slave number of the BS-46 that receives the command.

Note: This address is octal format, for example, BS-46 #15 would be 17 octal.

5. The Port Number is **Zero** for Channel 0.

The example below displays a Typed Read Message Instruction that reads 22 words from the "CO" Mode Results Buffer Channel #1 at address N145:128 of BS-46 Node ID #3. The data will be read to PLC Data Table Address N9:50.

The screenshot shows a software window titled "MSG - Rung #2:4 - MG9:1" with a "General" tab. The configuration is as follows:

- This PLC-5:**
 - Communication Command: PLC-5 Typed Read
 - Data Table Address: N9:50
 - Size in Elements: 22
 - Port Number: 0
- Target Device:**
 - Data Table Address: N145:128
 - Local Station Address (oct): 3 (dec): 3
 - Local / Remote: Local
- Control Bits:**
 - Ignore if timed out (TO): 0
 - To be retried (NR): 0
 - Awaiting Execution (EW): 0
 - Continuous Run (CO): 0
 - Error (ER): 0
 - Message done (DN): 0
 - Message Transmitting (ST): 0
 - Message Enabled (EN): 0
- Error:**
 - Error Code(Hex): 92
- Error Description:**
 - no response (regardless of station type)

Results Buffer "CO" Mode

Word 1 High Byte = message type (values 3,4,5,6)

- If value is 3 = Command 1 for Channel #1.
- If value is 4 = Command 1 for Channel #2.
- If value is 5 = Command 2 for Channel #1.
- If value is 6 = Command 2 for Channel #2.

Word 2 Low Byte = event counter per message type.

If value for Word 2 = 0, correct message type.

If value is not equal to zero, then the fault type is contained in the Low Byte.

If Word 2 **is not** equal to zero, then the following data is not valid.

Word 3++ = Read or Written data.

The example below displays the PLC-5[®] Data Table Addresses N9:50 - N9:71, which contains the "CO" Results Buffer of the previous example's "CO" Command Code of a Write operation. The High Byte of word N9:50 is a 03H, showing Command 1 for Channel #1 was executed. The Low Byte of word N9:50 is a 02H, which means the results are from the second event for that "CO" Command Buffer. The PLC-5[®] address N9:51 is of value 00H, which signifies there were no errors within the execution of the operation. Addresses N9:52 - N9:71 are the data values written to the TAG.

Offset	0	1	2	3	4	5	6	7	8	9
N7:0	2	3	14	5	101	101	101	101	101	101
N7:10	101	101	101	101	101	101	101	101	101	101
N7:20	101	101	101	101	0	0	0	0	0	0
N7:30	0	0	0	0	0	0	0	0	0	0
N7:40	0	0	0	0	0	0	0	0	0	0
N7:50	302	0	101	101	101	101	101	101	101	101
N7:60	101	101	101	101	101	101	101	101	101	101
N7:70	101	101	0	0	0	0	0	0	0	0
N7:80	0	0	0	0	0	0	0	0	0	0
N7:90	0	0	0	0	0	0	0	0	0	0

File N7 (hex) -- INTEGER

Radix: Hex/BCD

Columns: 10

Symbol: N7

Desc:

Properties Usage Help

Faults "CO" Mode

The Low Byte of "CO" results in Word 2, if value is not equal to zero:

Fault Code "CO" Mode	Description
9FH	Dialogue impossible to complete
9CH	Transceiver fault
9EH	Invalid data in the TAG
9BH	Addressing error
90H	Configuration error

"CO" Operation Mode:

"CO" Operation Mode can perform 2 command operations for each Channel. The operation is initiated either by the command being sent on the serial link or setting a parallel input high when the TAG is present. Once the command is executed, the ENR output is set high. The "CO" Mode Results Buffer must then be read to retrieve the data to the PLC and to reset the BS-46 to execute another "CO" Mode operation. After the "CO" Mode Results Buffer is read, the ENR output will be reset low.

Whichever "CO" Command Buffer is programmed first will execute first. Each "CO" Command Buffer operates separately from one another and each has its own event counter.

The "CO" Mode Results Buffer can contain the results of Command 1 or Command 2.

Channel #1	Output
Transceiver 1	Terminal A3 (ENR1)
Transceiver 2	Terminal A7 (ENR2)

Note: The BS-46 is not reset if the "CO" Mode Results Buffer is read short of the amount of data in the buffer equal to the previous operation. The read must be greater by 2 words than the data that was previously read. After the results are read, the data is stored in the Historic Buffer. The "CO" Mode Results Buffer is reset to zero once the "CO" Mode is activated, as the TAG leaves the zone.

Serial Link Operation "CO" Mode

The serial link function does one operation per serial command. Once the operation has executed, another serial message must be sent to do another operation. The best use for the "CO" Mode serial link command is to perform a Read or Write TAG with wait operation.

Example:

1. The "CO" Command Buffer 1 (Channel #1) was sent a serial command to **Read a TAG with Wait**. Then "CO" Command Buffer 2 (Channel #2) was sent a serial command to **Write a TAG with Wait**.
2. A TAG enters the Transceiver zone. Since it was programmed first, Command Buffer 1 (Channel #1) executes a Read TAG command. The ENR output goes high when the operation finishes.
- 3A. **Condition 1:** The "CO" Results Buffer is read while the TAG is still in the Transceiver zone.
Results 1: The ENR output goes low, the "CO" Command Buffer 2 Write TAG command executes. Once completed, the ENR output goes high and the "CO" Results Buffer must be read. Once the "CO" Results Buffer is read, there will be no other operation performed until another serial message is sent to either Command Buffer.
- 3B. **Condition 2:** The "CO" Results Buffer is read when the TAG has already left the Transceiver zone.
Results 2: The ENR output goes low and will stay low until another TAG enters the Transceiver zone. Once a TAG enters the Transceiver zone, the "CO" Command Buffer 2 Write TAG command executes and the ENR output goes high. Once the "CO" Results Buffer is read, there will be no other operation performed until another serial message is sent to either Command Buffer.

Parallel Input Operation "CO" Mode

Once programmed, the Parallel "CO" Mode will repeat the operation until power is cycled or another command is sent. This mode is useful when the order of events require control.

Parallel Input to Trigger "CO" Command:

Channel	Input
Transceiver 1 Command 1	Terminal B2 - DCY11
Transceiver 1 Command 2	Terminal B3 - DCY12
Transceiver 2 Command 1	Terminal B6 - DCY21
Transceiver 2 Command 2	Terminal B7 - DCY22

Example:

1. The "CO" Command Buffer 1 is programmed to **Read a TAG without Wait** when the parallel input Terminal B2 (DCY11) is set high.

The "CO" Command Buffer 2 is programmed to **Write a TAG without Wait** when the parallel input Terminal B3 (DCY12) is set high.
2. A TAG enters the Transceiver zone. If Terminal B2 (DCY11) is set high, then the Read operation will execute. If Terminal B3 (DCY12) is set high, then the Write operation will execute.
3. After a command has been executed, both parallel inputs are without effect until the "CO" Results Buffer has been read.
4. If a TAG is present after the "CO" Results Buffer has been read, then another input can be set high to trigger either of the commands. If a TAG is not present after the "CO" Results Buffer has been read, then the inputs are without effect.

Note: A TAG must be present when the BS-46 is programmed for parallel input "CO" Mode to trigger the command into action. The TAG presence output can be hard wired into a parallel input in order to trigger one of the "CO" Command Buffer's Command, to execute each time a TAG arrives in station. The parallel inputs are without effect until the results of the previous command is read.

Operation

The BS-46 can operate in three different Modes: Direct Access, Automatic Read and Controlled Operating.

Question: Which Mode is best for my application?

Answer: More than one mode may work for your application. For simplicity, "DA" Mode is the best. For Read-Only type applications when discontinuous block reads are needed, "AR" Mode may be the best. For applications where specific operations need to be performed, pending conclusions of other operations, then "CO" Mode is useful.

Question: Can two or more Modes be programmed and operate at once?

Answer: Yes, all three modes can be used at one station. If "AR" Mode and "CO" Mode are both programmed to do an operation when a TAG arrives, the first one carried out is the "AR" Mode, followed by the first programmed "CO" Mode Command Buffer's operation. "DA" Mode can be executed any time between or after the reading of the Result Buffers.

Data Formatting:

Data that is returned from a TAG Read is a "first read-first in" scheme. This means the TAG address byte read first (which is the Destination Data Table Address in the Typed Read Message Instruction) will appear in the first word's High Byte in the PLC Data Table (which is the Data Table Address in the Typed Read Message Instruction). The same is true for a Write to a TAG. The High Byte of the first word in the PLC Data Table (the Data Table Address in the Typed Write Message Instruction) will be written to the byte of the TAG beginning at the Destination Data Table Address in the Typed Write Message Instruction used.

Possible Allen Bradley Error Codes of a Message Instruction:

Error Code: 241d or F00Bh - Privilege error, access denied.

Possible cause - BALOGH Transceiver to TAG communication error, should read BS-46 Fault Code Buffer to retrieve BALOGH Fault Code.

Error Code: 146d or 0092h - No response (regardless of station type).

Possible cause - not communicating with the BS-46 due to improper hardware or software configuration. Check DIP switch settings, Node ID addresses, baud rate, and cable connections.

BS-46 JBUS[®] / MODBUS[®] Protocol

BALOGH

7699 Kensington Court
Brighton, MI 48116-8561
(248) 486-7343

Reminder about the JBUS[®] / MODBUS[®] Protocol

The maximum length per message is 256 bytes (including service bytes).

Implemented requests are only:

- Function 3 or 4: Read request of "N" words
- Function 6: Write request of one word
- Function 16: Write request of "N" words

Read Request of "N" Words

Request:

NE 1 byte	CF 1 byte	Ad 2 bytes HB LB	NB 2 bytes HB LB	CRC16 2 bytes
---------------------	---------------------	-------------------------------	-------------------------------	-------------------------

NE Slave number for BS-46 under MODBUS[®] Protocol
 CF Function number = 3 or 4
 Ad Address for the first word to be read
 NB Word number to read
 HB High Byte
 LB Low Byte
 CRC16 Check word

Response:

NE 1 byte	CF 1 byte	BC 1 bytes	D0.... 2 bytes...	Dn 2 bytes	CRC16 2 bytes
---------------------	---------------------	----------------------	-----------------------------	----------------------	-------------------------

BC Number of Read bytes
 D0 First read word (HB = 1st byte; LB = 2nd byte)
 Dn last read word Last read word

JBUS[®] is a trademark of APRIL Corporation
 MODBUS[®] is a trademark of Group Schneider Corporation (MODICON)

Write Request of "N" Words

Request:

NE 1 byte	CF 1 byte	Ad 2 bytes HB LB	N 2 bytes HB LB	BC 1 bytes	D0.... 2 bytes...	Dn 2 bytes	CRC16 2 bytes
---------------------	---------------------	-------------------------------	------------------------------	----------------------	-----------------------------	----------------------	-------------------------

NE: Slave number for BS-46 under MODBUS® Protocol
CF: Function number = 16
Ad: First address which must be written
N: Words quantity to write (N< 120)
BC: Quantity of bytes to write (BC = 2N: BC<240)
D0: First value to write
Dn: Last value to write

Response:

NE 1 byte	CF 1 byte	Ad 2 bytes	N 2 bytes	CRC16 2 bytes
---------------------	---------------------	----------------------	---------------------	-------------------------

Ad: Address of the first written word
N: Quantity of written words (N<120)

Write Request of One Word

Request:

NE 1 byte	CF 1 byte	Ad 2 bytes HB LB	D 2 bytes HB LB	CRC16 2 bytes
---------------------	---------------------	-------------------------------	------------------------------	-------------------------

NE: Slave number of BS-46
CF: Function code = 6
Ad: Address to write
D: Value (word) to be written

Response:

NE 1 byte	CF 1 byte	Ad 2 bytes	D 2 bytes	CRC16 2 bytes
---------------------	---------------------	----------------------	---------------------	-------------------------

Fault Indications

Under MODBUS[®] Protocol, when BS-46 finds a mistake, it gives back a fault message as following:

NE 1 byte	CD 1 byte	CE 2 bytes	CRC16 2 bytes
---------------------	---------------------	----------------------	-------------------------

NE: Slave number

CD: Code of the requested function + 128

CE: Fault indication:

- 1: Unknown function
- 2: Inadequate address or fault in the message
- 3: Inadequate data
- 4: Device not ready (or the TAG is not present)
- 8: Fault in the Write operation

Note: In case of wrong CRC16, the BS-46 does not answer to the request.

Addressing under MODBUS® Protocol

The BS-46 interface accepts the connection for 2 Transceivers, which are able to run simultaneously. The addressing for Channel #1 can be obtained by the following 2 ways:

1.) Slave number $NE = 2n^* + 1$

- a) The address (1) of the words is comprised between 0 and 7FFFH: the command must be executed by Transceiver 1.
- b) For Channel #2, the addresses must be added with 8000H (from 8000H to FFFFH).

2.) Slave number $NE = 2n^* + 2$: The command must be executed by Transceiver 2.

The BS-46 accepts, under MODBUS® Protocol, two slave numbers: $[2n+1]$ and $[2n + 2]$.

*n: Is defined by the 4 switches SLV

*(1): See addresses of the BS-46

Switches SLV

Off = 0

SW1	SW2	SW3	SW4	N	NE	
					TR1	TR2
OFF	OFF	OFF	OFF	0	1	2
ON	OFF	OFF	OFF	1	3	4
OFF	ON	OFF	OFF	2	5	6
ON	ON	OFF	OFF	3	7	8
OFF	OFF	ON	OFF	4	9	10
ON	OFF	ON	OFF	5	11	12
OFF	ON	ON	OFF	6	13	14
ON	ON	ON	OFF	7	15	16
OFF	OFF	OFF	ON	8	17	18
ON	OFF	OFF	ON	9	19	20
OFF	ON	OFF	ON	10	21	22
ON	ON	OFF	ON	11	23	24
OFF	OFF	ON	ON	12	25	26
ON	OFF	ON	ON	13	27	28
OFF	ON	ON	ON	14	29	30
ON	ON	ON	ON	15	31	32

Direct Access Mode (“DA” Mode)

The BS-46 interface accepts 2 Transceivers, which are able to work simultaneously and independently. In order to communicate with Channel #2:

- The addresses must be added with 8000H, for the same slave number ($NE = 2n+1$)

OR

- The slave number is $NE = 2n+2$

Steps:

- TAG Read or Write request
- TAG Reading or Writing
- Confirm of the operation or fault message

The "DA" Mode needs the presence of a TAG:

- If TAG is not present, the BS-46 gives back the fault 04.
- In case of anomaly relating to the identification system, the BS-46 gives back the fault 08. In this case, it's necessary to read the word 2100H (for Channel #1): High Byte contains the type of fault:

9BH	Invalid address for the TAG type
9CH	Fault with Transceiver or Transceiver linking
9EH	Invalid data in the TAG
9FH	Dialogue impossible to complete

TAG	Memory Availability	Memory Mode	Addressing (In bytes)
OF	7 bytes	Factory Programmed	0 to 6
OFR	7 bytes	User Re-Programmable	0 to 6
OMA	64 bytes	Ferro-Electric	2048 to 2112
	2K bytes		0 to 2047
	8K bytes		0 to 8180
OMX	8K bytes	Ferro-Electric	0 to 8180
	32K bytes		0 to 32767
GIE	512 bytes	Ferro-Electric	0 to 511
	2K bytes		0 to 2047
	8K bytes		0 to 8180
OIR	32K bytes	Ferro-Electric	0 to 32767
OP*	64 bytes	EEPROM	0 to 63 (Read)
			12 to 75 (Write)
OL	2 bytes	Factory Programmed	0 to 1
OLR	2 bytes	User Re-Programmable	0 to 1

* Note: Must Read/Write in blocks of (4) bytes to OP TAG

Automatic Reading Mode (“AR” Mode)

The "AR" Mode allows you to read the TAG in several non-successive zones (max. 5 zones).
These zones are defined by:

- Words quantity
- Address of the first word to be read

Max. 64 words (128 bytes) can be read.

Steps:

- The command to be executed is written in the specific buffer
- TAG Reading as soon as the TAG arrives in the zone of the Transceiver
- Read data is stored in a Result Buffer until read by PLC

Addresses:

	Channel #1	Channel #2 (+ 8000H)
Command Buffer	2000H to 207FH	A000H to A07FH
Result Buffer	2200H to A227FH	A200H to A27FH

Command:

M1 1 st word	Command word (1)	
M2 2 nd word	Length of the zone	Zone 1 in the TAG
M3 3 rd word	Addition of the 1st word	
M4 4 th word	Addition of the 1st word	
	Maximum 5 zones	

(1) Command word

- a) BIT 0 bit 0 = 1 => This reading operation must be automatically executed again for each new TAG.
bit 0 = 0 => Only one operation
- b) BIT 1 bit 1 = 1 => Immediate operation if a TAG is already in the field of the Transceiver. Automatically reset (=0) after operation; this bit will be set to 1:
- if a new operation is requested (disappearance of the TAG)
 - or by a message on the serial link (if bit = 0)

Recommended values: 2 or 3

Contents of Results Buffer in "AR" Mode

1st word (M1):

- HB => Message type (see p 26)
 - = 1 Automatic Reading for Channel #1
 - = 2 " for Channel #2
- LB = Event counter per message type (see HB)

2nd Word (M2):

- = 0 => Correct message
 - ≠ 0 => Fault type is contained in the Low Byte
- If this word is not zero, the following data is not valid.

Following words: M3...to Mn

Read or Written data

Operating

As soon as the function is executed or a fault is seen, the output SURV will be set (= 1). The Read data is stored in the Historic Buffer, after the result is asked by the user or the output SURV is reset (= 0).

The BS-46 is ready for a new operation when the TAG is not present anymore, and if the respective Result Buffer, the Cumul Buffer, or the General Buffer is read.

The Result Buffer is reset only if:

- The result is given back (buffer reading)
and
- A new operation is required (disappearance of the TAG)

Faults

The Low Byte of the 2nd word in the Result Buffer contains the fault type (if not zero):

9 FH	= Dialogue impossible to complete
9 CH	= Transceiver fault
9 EH	= Incoherent data in the TAG
9 BH	= Addressing error
9 0H	= Configuration error

Controlled Operating Mode (“CO” Mode)

The command to execute (if a "/" input or an internal bit is set with the serial link) is written in a dedicated buffer (TAG Reading or Writing). After operation, the result is stored in a dedicated buffer.

Addresses:

	Channel #1	Channel #2 (+8000H)
Command 1 Buffer	2080H to 20FFH	A080H to A0FFH
Command 2 Buffer	2180H to 21FFH	A180H to A1FFH
Results Buffer	2280H to 22FFH	A280H to A2FFH

Command:

M1 1st word	Command Word	(1)
M2 2nd word	Function	(2)
M3 3rd word	Quantity of words to be Read or Written	(3)
M4 4th word	First address of the zone	
M5 5th word	(...data if Write request)	

(1) 1st word = Command Word (M1)

BIT 0 bit 0 = 1 => Operation to be executed
 if E1 = 1 or E2 = 1 for Channel #1
 if E5 = 1 or E6 = 1 for Channel #2
 bit 0 = 0 => The input is without effect

BIT 1 bit 1 = 1 => Operation to be executed immediately with or without waiting for the TAG.
 Automatically reset (= 0) after the operation, the bit 1 will set again (=1):
 - if a new operation is asked ("/" input is = 1)
 - or by the serial link (if bit 0 = 0)

Recommended values: 1 or 2

Input E1 (E5) starts the Command 1 for Channel #1 (Channel #2)
Input E2 (E6) starts the Command 2 for Channel #1 (Channel #2)

(2) 2nd word = function to realize (M2)

BIT 0 - bit 0 = 0 => TAG Reading
 - bit 0 = 1 => TAG Writing

BIT 1 - bit 1 = 0 => without waiting for TAG
 - bit 1 = 1 => with waiting for TAG

Contents of Results Buffer in "CO" Mode

1st word (M1): High Byte	=	Message type		
= 3	=	Command	1	for Channel #1
= 4	=	"	1	for Channel #2
= 5	=	"	2	for Channel #1
= 6	=	"	2	for Channel #2
Low Byte	=	Event counter per message type (see HB)		

2nd word (M2):

- = 0	=>	Correct message
- not = 0	=>	Fault type is contained in the Low Byte

If this word is not zero, the following data is not valid.

Following words (M3...to Mn):

Read or Written data

Operating

For each Channel, the "CO" Mode Result Buffer can contain the results of Command 1 or Command 2.

After the command is executed, the output ENR will be set (=1), and it will be reset (= 0) after the result is read or automatically sent.

The "/" inputs are without effect, as long as the result of the previous command is not read.

After the results are read, the data is stored in the Historic Zone.

The standard Result Buffer is reset (=0) only if:

- The result is given back (read by PLC) and,
- A new operation is required (a "/" input or an internal bit is activated)

Faults

The Low Byte of the 2nd word in the Result Buffer contains the fault type (if not zero).

- 9 FH = Dialogue impossible to complete
- 9 CH = Transceiver fault
- 9 EH = Incoherent data in the TAG
- 9 BH = Addressing error
- 9 0H = Configuration error

Contents of a "Historic Buffer"

1st word (M1)	- M1 = FFFFH => There was no automatic results giving back - M1 not = FFFFH => Results were automatically sent
2nd word (M2)	- High Byte HB = Message type - Low Byte LB = Message counter (per type)
3rd word (M3)	- M3 = 0 => Correct message - M3 not = 0 => Then the fault number is contained in Low Byte and the following data are not valid
4th word (M4) (Mn)	-Read or Written data

Message Type

1	"AR" Mode Command for Channel #1
2	"AR" Mode Command for Channel #2
3	"CO" Mode Command 1 for Channel #1
4	" 1 "
5	" 2 "
6	" 2 "
7	(Only valid for the Cumul Buffer) Buffer overflow relating to the results of the 2 Channels.

BS-46

Communications with
Allen Bradley SLC-503/504[®] Series,
Channel-Zero, using
Data-Highway Plus[®]
Message Instructions
“Peer To Peer”

BALOGH

7699 Kensington Court
Brighton, MI 48116-8561
(248) 486-7343

Overview about the DF1[®] & DH+[®] Protocol

The BS-46 can be configured as a serial interface slave unit that allows communication with all styles of BALOGH'S electronic TAGS. This can be done through connection to the Channel 0 port on Allen Bradley's SLC 503[®]/504[®] using DH+[®] Typed Read and Typed Write Message Instructions via RS-232. The BS-46 operates in three Modes: Direct Access, Automatic Read, and Controlled Operating.

Hardware Configuration:

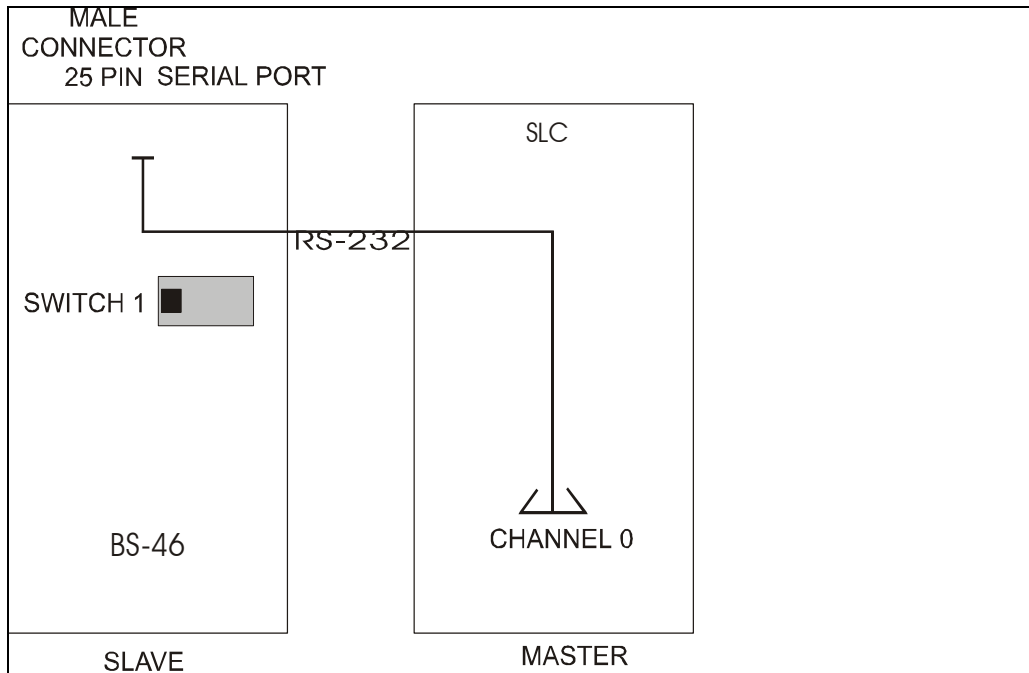

Pin Connections - RS-232 Connectors for cable

BS-46 (Female 25- Pin)		SLC-503/504 [®] (Female 9- Pin)
Pin 2	→	Pin 2
Pin 3	→	Pin 3
Pin 7	→	Pin 5

Protocol DIP Switch Settings for BS-46 to SLC-503/504[®]

Protocol	SW1	SW2	SW3	SW4
DH+ CH0	ON	OFF	ON	OFF

Channel 0 Configuration

When creating a new file for the SLC, you must make sure that Channel 0 is configured correctly. The following steps will take you through configuring Channel 0.

From the Monitor File screen:

Select < F7 > General Utility

Your screen will not change, instead you will receive a new set of “F” key options.

Select < F5 > Channel Configuration

Your screen will change to: **Channel Configuration**

Check to make sure the following is configured correctly:

Channel 0 Configuration:

Current Communication Mode:	System
System Mode Driver:	DF1 Full Duplex
User Mode Driver:	Generic ASCII
Write Protect:	Enabled
Mode Changes:	Enabled
Mode Attention Character:	\1b
System Mode Character:	S
User Mode Character:	U
Edit Resource/ File Owner Timeout:	60 (Seconds)
Pass Thru Link ID:	1

(Channel 1 is not used with the BS-46 to communicate with the SLC)

Select < F4 > Ch 0 System Configuration

Screen will change to: **Channel 0 System Mode Configuration**

Check to make sure the following is configured correctly.

Communication Driver:	DF1 Full- Duplex	Parity:	Even
Diagnostic File:	Reserved		
Baud Rate:	19200	Error Detect:	BCC
Duplicate Detect:	Enabled	NAK Retries:	3
ACK Timeout [x20 ms]:	50	ENQ Retries:	3
Source ID:	9	Embedded Responses:	Enabled
Control Line:	No Handshaking		

Select < F1 > Accept Edits, screen will change to Channel Configuration.

Select < F1 > Accept Edits again to save changes and return to Monitor File.

* An error code 0007 (Hex) or 0008 (Hex) will appear in the Message Instruction if Channel 0 is not configured correctly.

Software Configuration

Note: The software configuration text and screen captures are based on the Allen Bradley APS® Series Software Product Release 5.01. Refer to Allen Bradley's Advanced Programming Software Users Manual for complete programming instructions.

To configure the Software for the BS-46, complete the following steps:

A Message Instruction Block must be inserted into a program ladder logic rung to program the BS-46 for either Direct Access, Automatic Reading, or Controlled Operating Mode. After creating the Message Control Block, complete the following steps:

1. Select <F1> to choose a Read action, or <F2> to choose a Write action.
2. Select <F3> PLC-5® to designate the target device (this is the how the BS-46 is addressed by the SLC-503/504®).
3. Select <F1> Local.
4. Enter a user defined Control Block "N" file for the Message Instruction, press [Enter]. (Display will change to the second part of the Message Instruction screen). The amount of words the Message Instruction will require is 14 words for each Message Instruction.

Note: Below is an example of how the first page of a Message Instruction would look. It will allow users to designate if:

1. Read or Write Function is Performed
2. Target Device Designation
3. Local or Remote Operation
4. Control Block Address
5. Control Block Length in Words

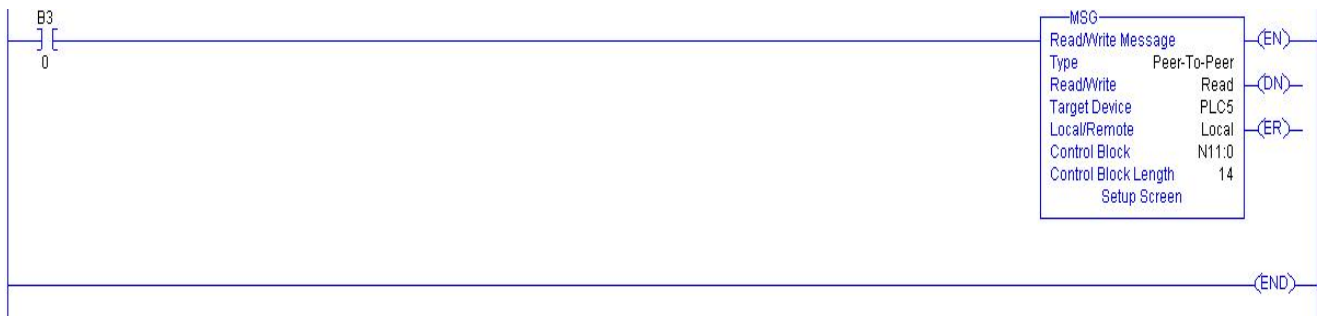

5. The <F10> Channel Setting and the <F1> Target Node setting should be set to 0.
6. The source file, destination files, and message length parameters will be set according to the Mode of operation: **Direct Access (“DA”)**, **Automatic Reading (“AR”)**, or **Controlled Operating (“CO”)**. These Modes and files are further described later in this manual.
7. After selecting the files and length of elements, press [Enter] to save and exit.
8. Press [Enter] to change the <F> key options.
9. Selecting <F10> accepts the rung.
10. Selecting <F9> Test Edits.
11. Selecting <F8> verifies that yes, you wish to test the edits.

Your Message Instruction is complete.

Note: Below is an example of how the second page of a Message Instruction would look. It will allow users to designate if:

1. Read or Write Function is performed
2. Destination File Address (SLC Data Table)
3. Target Source File Address (BS-46 Channel designation & TAG or buffer address)
4. Message Length in Elements (each word equals two bytes)

Message Setup

General

Type: Peer-To-Peer
 Read/Write: Read
 Target Device: PLC5
 Local/Remote: Local
 Control Block: N14:0
 Channel: 0
 Target Node (decimal): 0 (0 Octal)
 Local File Address: N7:0
 Targets File Address/Offset: N164:0
 Message Length in Elements: 10
 Message Timeout (Seconds): 0

Control Bits

Ignore if timed out (TO): 0
 To be retired (NR): 0
 Awaiting Execution (EW): 0
 Continuous Run (CO): 0
 Error (ER): 0
 Message done (DN): 0
 Message Transmitting (ST): 0
 Message Enabled (EN): 0
 Waiting for queue space: 0

Control Address: N14:0

Error

Error Code(Hex): 0

OK
 Cancel
 Help

Error Description

BS-46 Addressing

The following tables represent a range of integer files used to address the BS-46's internal programming buffers. These files allow the BS-46 to appear as if it was a PLC-5® to the SLC.

Note: The files below do not need to be created, and should not be confused with data table files in the users Host PLC.

Transceiver Channel #1:

Designation Channel #1	Start Address	End Address
Command Buffer for "AR" Mode	N32:0	N32:127
Command Buffer for "CO" Mode	N32:128	N32:255
High Byte=0 or fault value in "DA" Mode Low Byte =image of output	N33:0	-----
High Byte=0 Low Byte =image of inputs	N33:1	-----
2nd Command Buffer "CO" Mode	N33:128	N33:255
Results Buffer for "AR" Mode	N34:0	N34:127
Results Buffer for "CO" Mode	N34:128	N34:255
General Buffer Holds every result for both Channels	N35:0	N35:127
Cumul Buffer Holds results for both Channels	N35:128	N35:255
Historic Buffer event (1)	N48:0	N48:127
Historic Buffer event (2)	N48:128	N48:255
Historic Buffer event (3)	N49:0	N49:127
Historic Buffer event (4)	N49:128	N49:255
Historic Buffer event (5)	N50:0	N50:127
Historic Buffer event (6)	N50:128	N50:255
Historic Buffer event (7)	N51:0	N51:127
Historic Buffer event (8)	N51:128	N51:255

Transceiver Channel #2:

Designation Channel #2	Start Channel	End Address
Command Buffer for "AR" Mode	N96:00	N96:127
Command Buffer for "CO" Mode	N96:128	N96:255
High Byte=0 or fault value in "DA" Mode Low Byte-image of outputs	N97:0	-----
High Byte=0 Low Byte =image of inputs	N97:1	-----
2nd Command Buffer "CO" Mode	N97:128	N97:255
Results Buffer for "AR" Mode	N98:00	N98:127
Results Buffer for "CO" Mode	N98:128	N98:255
General Buffer holds every result for both Channels	N99:00	N99:127
Cumul Buffer holds results for both Channels	N99:128	N99:255
Historic Buffer event (1)	N112:00	N112:127
Historic Buffer event (2)	N112:128	N112:255
Historic Buffer event (3)	N113:00	N113:127
Historic Buffer event (4)	N113:128	N113:255
Historic Buffer event (5)	N114:00	N114:127
Historic Buffer event (6)	N114:128	N114:255
Historic Buffer event (7)	N115:00	N115:127
Historic Buffer event (8)	N115:128	N115:255

Direct Access Mode (“DA” Mode)

Direct Access Mode can be used to read data from a TAG with a **Typed Read** Message, directly into the SLC 5/03[®] or SLC 5/04[®] Data Table, defined as the **Destination File Address**. The "DA" Mode can also write data directly from the SLC Integer Data Table to a TAG with a **Typed Write** message. The data table that contains the information to write is defined as the **Source File Address**. In the Direct Access Mode, the BS-46 acts as a pass through device for the command. It holds no program within its own memory.

Note: During any "DA" Mode operation, the TAG must be present or a time out error will occur in the SLC Message Instruction. This causes a communications fault in the BS-46's "DA" Mode Fault Buffer.

The following table describes the mapping of the TAG memory. The address ranges shown are used as the Target File Addresses when reading or writing the TAG in the Direct Access Mode.

"DA" Mode SLC 5/03[®] & 5/04[®] with OMA 64 Byte TAG Addressing:

64 byte Channel #1	Memory Range (In bytes)	64 byte Channel #2
N164:0 - N164:32	0 - 64	N228:0 - N228:32

"DA" Mode SLC 5/03[®] & 5/04[®] with OMA 2K Byte TAG Addressing:

OMA 2K TAG Channel #1	Memory Range (In Bytes)	OMA 2K TAG Channel #2
N160:0 - N160:255	0 - 512	N224:0 - N224:255
N161:0 - N161:255	513 - 1024	N225:0 - N225:255
N162:0 - N162:255	1025 - 1536	N226:0 - N226:255
N163:0 - N163:253	1537 - 2044	N227:0 - N227:253

SLC-5/03[®] & SLC-5/04[®] with OMA 8K TAG Addressing:

OMA 8K TAG Channel #1	Memory Range (In bytes)	OMA 8K TAG Channel #2
N176:0 - N176:255	0 - 512	N240:0 - N240:255
N177:0 - N177:255	513 - 1024	N241:0 - N241:255
N178:0 - N178:255	1025 - 1536	N242:0 - N242:255
N179:0 - N179:255	1537 - 2048	N243:0 - N243:255
N180:0 - N180:255	2049 - 2560	N244:0 - N244:255
N181:0 - N181:255	2561 - 3072	N245:0 - N245:255
N182:0 - N182:255	3073 - 3584	N246:0 - N246:255
N183:0 - N183:255	3585 - 4096	N247:0 - N247:255
N184:0 - N184:255	4097 - 4608	N248:0 - N248:255
N185:0 - N185:255	4609 - 5120	N249:0 - N249:255
N186:0 - N186:255	5121 - 5632	N250:0 - N250:255
N187:0 - N187:255	5633 - 6144	N251:0 - N251:255
N188:0 - N188:255	6145 - 6656	N252:0 - N252:255
N189:0 - N189:255	6657 - 7168	N253:0 - N253:255
N190:0 - N190:255	7169 - 7680	N254:0 - N254:255
N191:0 - N191:253	7681 - 8188	N255:0 - N255:253

"DA" Mode SLC-5/03® & SLC-5/04® with OMX 8K TAG Addressing:

OMX 8K TAG Channel #1	Memory Range (In bytes)	OMX 8K TAG Channel #2
N160:0 - N160:255	0 - 512	N224:0 - N224:255
N161:0 - N161:255	513 - 1024	N225:0 - N225:255
N162:0 - N162:255	1025 - 1536	N226:0 - N226:255
N163:0 - N163:255	1537 - 2048	N227:0 - N227:255
N164:0 - N164:255	2049 - 2560	N228:0 - N228:255
N165:0 - N165:255	2561 - 3072	N229:0 - N229:255
N166:0 - N166:255	3073 - 3584	N230:0 - N230:255
N167:0 - N167:255	3585 - 4096	N231:0 - N231:255
N168:0 - N168:255	4097 - 4608	N232:0 - N232:255
N169:0 - N169:255	4609 - 5120	N233:0 - N233:255
N170:0 - N170:255	5121 - 5632	N234:0 - N234:255
N171:0 - N171:255	5633 - 6144	N235:0 - N235:255
N172:0 - N172:255	6145 - 6656	N236:0 - N236:255
N173:0 - N173:255	6657 - 7168	N237:0 - N237:255
N174:0 - N174:255	7169 - 7680	N238:0 - N238:255
N175:0 - N175:253	7681 - 8188	N239:0 - N239:253

Reading a TAG in "DA" Mode

The Typed Read Message Instruction is used to read data from a TAG.

The setup is as follows:

1. The Channel Number is **Zero** for Channel 0.
2. The Destination File Address is where the data Read from the TAG appears in the SLC after the read is completed.
3. The Target Source File Address is the starting TAG address and Channel Number to begin reading.
4. The Size in Elements is the number of words that are read from the TAG. Each word equals 2 bytes of data.

The Typed Read Message Instruction in the example below displays a direct Read of 10 words (20 bytes) starting at byte 0 of an OMA 64 byte TAG on Transceiver Channel #1 of the BS-46. The TAG data will be read to the SLC Destination File Address N7:0.

The screenshot shows a 'Message Setup' dialog box with the following configuration:

- General:**
 - Type: Peer-To-Peer
 - Read/Write: Read
 - Target Device: PLC5
 - Local/Remote: Local
 - Control Block: N14:0
 - Channel: 0
 - Target Node (decimal): 0 (0 Octal)
 - Local File Address: N7:0
 - Targets File Address/Offset: N164:0
 - Message Length in Elements: 10
 - Message Timeout (Seconds): 0
- Control Bits:**
 - Ignore if timed out (TO): 0
 - To be retired (NR): 0
 - Awaiting Execution (EW): 0
 - Continuous Run (CO): 0
 - Error (ER): 0
 - Message done (DN): 0
 - Message Transmitting (ST): 0
 - Message Enabled (EN): 0
 - Waiting for queue space: 0
- Control Address:** N14:0
- Error:**
 - Error Code(Hex): 0
- Error Description:** (Empty text area)

Buttons: OK, Cancel, Help

Writing a TAG in "DA" Mode

The Typed Write Message Instruction is used to write data to a TAG:

The setup is as follows:

1. The Channel Number is **Zero** for Channel 0.
2. The Source File Address is where the data to be written to the TAG is stored in the SLC.
3. The Target Destination File Address is the starting TAG address and Channel Number to begin writing the data.
4. The Size in Elements is the number of words (each word equals 2 bytes) written to the TAG.

The example below displays a Typed Write Message Instruction for a direct write of 10 words (20 bytes) from SLC Source File Address N7:50 to an OMA 64 byte TAG on Transceiver Channel #1.

The screenshot shows a 'Message Setup' dialog box with the following fields and values:

Field	Value
Type	Peer-To-Peer
Read/Write	Write
Target Device	PLC5
Local/Remote	Local
Control Block	14:15
Channel	0
Target Node (decimal)	0 (0 Octal)
Our Source File Address	N7:50
Targets Destination File	N164:0
Message Length in Elements	10
Message Timeout (Seconds)	0
Ignore if timed out (TO)	0
To be retired (NR)	0
Awaiting Execution (EW)	0
Continuous Run (CO)	0
Error (ER)	0
Message done (DN)	0
Message Transmitting (ST)	0
Message Enabled (EN)	0
Waiting for queue space	0
Control Address	14:15
Error Code(Hex)	0

Buttons: OK, Cancel, Help

Fault Condition "DA" Mode

Note: The High Byte is the Fault Code. The Low Byte is the image output.

When Direct Access Mode is executed and a fault occurs in the Message Instruction (N33:0 for Channel #1 or N97:0 for Channel #2) of the BS-46, it can be read to detect the fault condition. Below is a list of the Fault Codes.

Fault Locations "DA" Mode:

Channel Number	BS-46 Address
Transceiver 1	N33:0
Transceiver 2	N97:0

Fault Codes:

Fault Code "DA" Mode High Byte	Description
9BH	Non-valid address for TAG type
9CH	Fault with Transceiver or Transceiver linking
9EH	Non-valid data in the TAG
9FH	Dialogue impossible to complete

Note: Data returned from a TAG Read function is a "first read-first in" scheme. Meaning the first byte read will appear in the first word's High Byte in the SLC Data Table. It will be written to the byte of the TAG beginning at the Destination File Address in the Typed Write Message Instruction used.

Automatic Reading Mode (“AR” Mode)

This mode executes the automatic reading of a TAG as it enters the designated Transceiver zone. Up to five memory zones can be read from the TAG in a single read. The total of all five zones must not be over 30 words. The **Typed Write** Message Instruction is used to program the BS-46 for the "AR" Mode. The **Typed Read** Message Instruction is used to read the "AR" Results Buffer and transfer the data from the BS-46 to the SLC after a TAG Read occurs.

Addressing "AR" Mode:

Command Buffer "AR" Mode Channel #1	N32:0 - N32:127
Command Buffer "AR" Mode Channel #2	N96:0 - N96:127
Results Buffer "AR" Mode Channel #1	N34:0 - N34:127
Results Buffer "AR" Mode Channel #2	N98:0 - N98:127

Command Code “AR” Mode:

Word 1	Command Word
Word 2	Number of words to Read in Zone 1
Word 3	TAG address of Zone 1 to begin Reading
Word 4 (optional)	Number of words to Read in Zone 2
Word 5 (optional)	TAG address of Zone 5 to begin Reading
Word 10 (optional)	Number of words to Read in Zone 5
Word 11 (optional)	TAG address of Zone 5 to begin Reading

Word 1 (Values 2 or 3)

The first word of data in the SLC Source File Address is the **Command Word** (2 bytes).

Command Word 1 = 2, Instructs a one time read with wait.
 Command Word 1 = 3, Instructs repeated reads with wait.

Note: Sending the Command Code to the BS-46 is a Typed Write Message Instruction. It is measured in words, not bytes. Reading the results from that action requires a Typed Read Message Instruction.

Word 2 "AR" Command Code

The second word in the SLC Source File Address is the length in words to be read from the TAG (maximum of 30). The "AR" Buffer is 32 words with 2 words reserved for status.

Word 3

The third word in the SLC Source File Address is the address of the TAG to begin the zone read.

TAG	Memory Availability	Memory Mode	Addressing (In bytes)
OF	7 bytes	Factory Programmed	0 to 6
OFR	7 bytes	User Re-Programmable	0 to 6
OMA	64 bytes	Ferro-Electric	2048 to 2112
	2K bytes		0 to 2047
	8K bytes		0 to 8180
OMX	8K bytes	Ferro-Electric	0 to 8180
	32K bytes		0 to 32767
GIE	512 bytes	Ferro-Electric	0 to 511
	2K bytes		0 to 2047
	8K bytes		0 to 8180
OIR	32K bytes		0 to 32767
OP*	64 bytes	EEPROM	0 to 63 (Read)
			12 to 75 (Write)
OL	2 bytes	Factory Programmed	0 to 1
OLR	2 bytes	User Re-Programmable	0 to 1

* Note: Must Read/Write in blocks of (4) bytes to OP TAG

These 3 words complete one "AR" Mode zone to read in the TAG.

Note:

- There can be up to 5 zones
- All 5 zones combined must not occupy over 30 words in a single read
- Using more than one zone relates to a discontinuous block read

The example below displays an "AR" Command Code string starting at N7:0, with repeated reads of 10 words (20 bytes) of a TAG, beginning at addresses 0, 20, and 40 each time a TAG enters the Transceiver zone. This "AR" Command Code string uses 3 zones of a possible 5 zones maximum.

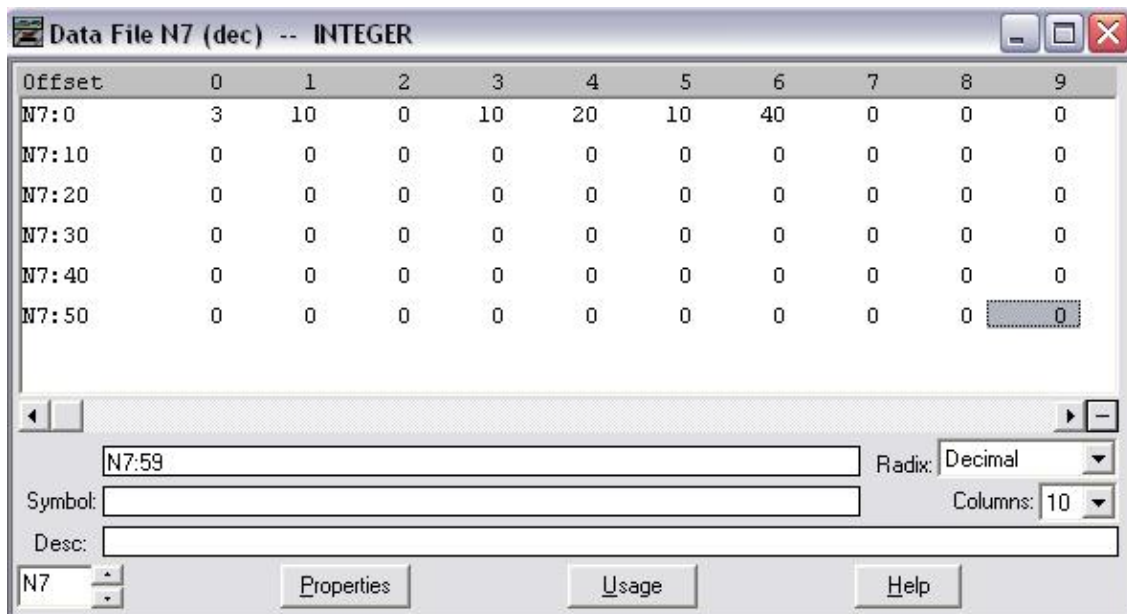

Writing to the "AR" Mode Buffer

The Typed Write Message Instruction is used to write the "AR" Command Code to the BS-46's "AR" Command Buffer:

1. The Channel Number is **Zero** for Channel 0.
2. The Source File Address is where the "AR" Command Code string is written from the SLC.
3. The Target Destination File Address is the address of the "AR" Command Buffer of the BS-46 where the data is written to.
4. The Size in Elements is the length in words of the "AR" Command Code string that is dependent on the number of zones used. One command set zone occupies three word elements. The maximum Size of Elements is 11 words using 5 zones and a minimum of 3 words using just one zone.

The example below displays a **Typed Write** Message Instruction that writes a "command string" of 7 Elements, located at SLC Source File N7:0 to N32:0, the "AR" Command Buffer for Channel #1 of the BS-46.

Note: The BS-46 needs to be programmed only once, even if programmed for multiple reads. However, it must be reprogrammed if power is recycled.

The screenshot shows a 'Message Setup' dialog box with the following configuration:

- General:**
 - Type: Peer-To-Peer
 - Read/Write: Write
 - Target Device: PLC5
 - Local/Remote: Local
 - Control Block: 11:15
 - Channel: 0
 - Target Node (decimal): 0 (0 Octal)
 - Our Source File Address: N7:0
 - Targets Destination File: N32:0
 - Message Length in Elements: 7
 - Message Timeout (Seconds): 0
- Control Bits:**
 - Ignore if timed out (TO): 0
 - To be retired (NR): 0
 - Awaiting Execution (EW): 0
 - Continuous Run (CO): 0
 - Error (ER): 0
 - Message done (DN): 0
 - Message Transmitting (ST): 0
 - Message Enabled (EN): 0
 - Waiting for queue space: 0
 - Control Address: 11:15
- Error:**
 - Error Code(Hex): 0
- Error Description:** (Empty text area)

Buttons: OK, Cancel, Help

Reading the "AR" Mode Buffer

The Typed Read Message Instruction is used to read the data into the SLC from the BS-46 "AR" Results Buffer:

1. The Channel Number is **Zero** for Channel 0.
2. The Destination File Address is where the data read from the buffer will be stored in the SLC.
3. The Target Source File Address is the address of the "AR" Results Buffer.
4. The Size in Elements is the number of words read from the "AR" Results Buffer. It must be greater by 2 than the number of words read from the TAG to account for 2 words of status, otherwise the BS-46 will not be reset to do another Automatic Read.

The example below displays a **Typed Read** Message Instruction that will read 32 words from the Channel #1 "AR" Results Buffer of the BS-46 to the SLC Address N7:20.

The screenshot shows a 'Message Setup' dialog box with the following fields and values:

Field	Value
Type	Peer-To-Peer
Read/Write	Read
Target Device	PLC5
Local/Remote	Local
Control Block	11:0
Channel	0
Target Node (decimal)	0 (0 Octal)
Local File Address	N7:20
Targets File Address/Offset	N34:0
Message Length in Elements	32
Message Timeout (Seconds)	0
Ignore if timed out (TO)	0
To be retired (NR)	0
Awaiting Execution (EW)	0
Continuous Run (CO)	0
Error (ER)	0
Message done (DN)	0
Message Transmitting (ST)	0
Message Enabled (EN)	0
Waiting for queue space	0
Control Address	11:0
Error Code(Hex)	0

Buttons: OK, Cancel, Help

Contents of Results Buffer in "AR" Mode

Word 1 High Byte = message type (value 1 for Channel #1 or value 2 for Channel #2), single and multiple reads.

Low Byte = Event counter per message type.

Word 2 If High Byte = 0, message is correct. If not equal to zero, fault type is contained in Low Byte.

Word 3++ Begins data Read from TAG.

The example below displays the "AR" Results Buffer starting at SLC Address N7:20. The first 2 words are status words. The High Byte of N7:20 (01H) stands for Channel #1. The Low Byte of N7:20 (03H) is the third event from which the "AR" Mode Results Buffer has read, since the "AR" Mode has been programmed into the BS-46. The value of 00H in N7:21 means there was not an error in the event. The data from address N7:22 to N7:52 is the data read from the TAG in the specified zones listed in the "AR" Command Code string example. The 1's came from TAG Zone 1, 2's from TAG Zone 2, and 3's from TAG Zone 3.

Offset	0	1	2	3	4	5	6	7	8	9
N7:0	3	A	0	A	14	A	28	0	0	0
N7:10	0	0	0	0	0	0	0	0	0	0
N7:20	0	0	1111	1111	1111	1111	1111	1111	1111	1111
N7:30	2222	2222	2222	2222	2222	2222	2222	2222	2222	2222
N7:40	3333	3333	3333	3333	3333	3333	3333	3333	3333	3333
N7:50	3333	3333	0	0	0	0	0	0	0	0

Symbol: Radix: Hex/BCD
Columns: 10

Buttons: Properties, Usage, Help

Faults "AR" Mode

Low Byte of "AR" Results Word 2:

Fault Code "AR" Mode	Description
9FH	Dialogue impossible to complete
9CH	Transceiver fault
9EH	Incoherent data in TAG
9BH	Addressing error
90H	Configuration error

Operation of "AR" Mode:

The BS-46 is programmed for "AR" Mode to do repeated reads.

TAG enters Transceiver zone or was already in zone at the time when "AR" Mode was issued. The TAG is read once, and the BS-46 sets SURV output high when complete.

Channel Number	Output
Transceiver 1	Terminal A2 - SURV1
Transceiver 2	Terminal A6 - SURV2

- Condition 1:** TAG still present and the "AR" Results Buffer is read.
Results 1: The "AR" Mode will not be reset to do another read until the TAG leaves the Transceiver zone. Once the TAG leaves, the SURV output drops low, the "AR" Mode is reset to do another read.
- Condition 2:** The TAG leaves the Transceiver zone before the "AR" Results Buffer is read.
Results 2: Once the "AR" Results Buffer is read, "AR" Mode is reset to do another read.
- Condition 3:** The TAG leaves the Transceiver zone before the "AR" Results Buffer is read and another TAG enters the zone.
Results 3: Once the "AR" Results Buffer is read, the "AR" Mode will be Reset and the TAG in zone will automatically be read.

Note: When the "AR" Mode is reset, the previous read data is stored in the Historic Buffer. The BS-46 can be reset by reading the Results Buffer, the Cumul Buffer or the General Buffer. Once the "AR" Mode is reactivated, the Results Buffer is reset to zero.

Controlled Operating Mode (“CO” Mode)

This mode executes a command stored in the "CO" Mode Command Buffer when a parallel input is set or by serial link. Results are stored in the "CO" Mode Results Buffer. A **Typed Write** Message Instruction is used to write the Command Code string to the BS-46. The **Typed Read** Message Instruction is used to read back the results once the operation is complete. Two Command Codes can be stored for each Channel.

Note: The BS-46 must be reprogrammed if power is cycled.

Addressing "CO" Mode:	
Command Buffer "CO" Mode Channel #1	N32:128 - N32:255
Command Buffer "CO" Mode Channel #2	N96:128 - N96:255
Results Buffer "CO" Mode Channel #1	N34:128 - N34:255
Results Buffer "CO" Mode Channel #2	N98:128 - N98:255

Command Code "CO" Mode	Description
Word 1	Command Word
Word 2	Function
Word 3	Quantity of words to be Read or Written
Word 4	TAG address to begin the Read or Write
Word 5++	(Data if a Write request)

Word 1 = Command Word (values 1 or 2)

If = 1, then command executes when corresponding input is set high. This command will stay in the BS-46 and will not need to be reset unless power is recycled.

Input Terminal B2 triggers Command 1 for Channel #1
 Input Terminal B3 triggers Command 2 for Channel #1
 Input Terminal B6 triggers Command 1 for Channel #2
 Input Terminal B7 triggers Command 2 for Channel #2

If = 2, then command executes immediately after the message is set by internal bit and must be reset after each performance.

Word 2 = Functions (values 0, 1, 2, 3)

If value is 0 = TAG Reading without wait.
 If value is 1 = TAG Writing without wait.
 If value is 2 = TAG Reading with wait.
 If value is 3 = TAG Writing with wait.

Word 3 = Quantity of words to be Read or Written.

30 words are the maximum for a Read command.
 30 words are the maximum for a Write command.

- The "CO" Mode Results Buffer is 32 words, with two words reserved for status. This reduces the read to 30 words.
- The "CO" Mode Command Buffer is 32 words, with 2 words reserved for the "CO" Command Code. This reduces the write to 30 words.

Word 4 = Address of TAG, "CO" Command Code.

TAG Addresses "CO" Mode:

TAG	Memory Availability	Memory Mode	Addressing (In bytes)
OF	7 bytes	Factory Programmed	0 to 6
OFR	7 bytes	User Re-Programmable	0 to 6
OMA	64 bytes	Ferro-Electric	2048 to 2112
	2K bytes		0 to 2047
	8K bytes		0 to 8180
OMX	8K bytes	Ferro-Electric	0 to 8180
	32K bytes		0 to 32767
GIE	512 bytes	Ferro-Electric	0 to 511
	2K bytes		0 to 2047
	8K bytes		0 to 8180
OIR	32K bytes	Ferro-Electric	0 to 32767
OP*	64 bytes	EEPROM	0 to 63 (Read)
			12 to 75 (Write)
OL	2 bytes	Factory Programmed	0 to 1
OLR	2 bytes	User Re-Programmable	0 to 1

* Note: Must Read/Write in blocks of (4) bytes to OP TAG

Word 5++ = Data if Write Request.

The example below displays a "CO" Command Code string beginning at N9:0, to do a TAG Write with wait sent to the BS-46 through the RS-232 serial link. The quantity of words written to the TAG is 20 words (or 14H) starting at TAG address 5. The data written to the TAG is 01H for each byte.

Offset	0	1	2	3	4	5	6	7	8	9
N7:0	2	3	14	5	101	101	101	101	101	101
N7:10	101	101	101	101	101	101	101	101	101	101
N7:20	101	101	101	101	0	0	0	0	0	0
N7:30	0	0	0	0	0	0	0	0	0	0
N7:40	0	0	0	0	0	0	0	0	0	0
N7:50	0	0	0	0	0	0	0	0	0	0
N7:60	0	0	0	0	0	0	0	0	0	0
N7:70	0	0	0	0	0	0	0	0	0	0
N7:80	0	0	0	0	0	0	0	0	0	0
N7:90	0	0	0	0	0	0	0	0	0	0

Writing to the "CO" Mode Buffer

The Typed Write Message Instruction is used to write the "CO" Command Code to the BS-46's "CO" Command Buffer:

1. The Source File Address is where the "CO" Mode Command Code string is entered in the SLC.
2. Size in Elements is the length in words of the "CO" Mode Command Code string.
3. The Target Destination File Address is the "CO" Mode Command Buffer of where the Command Code is written to.
4. The Channel Number is **Zero** for Channel 0.

The example below displays a **Typed Write** Message Instruction that writes 24 words to the Channel #1 "CO" Command 1 Buffer at Address N32:128. This includes the "CO" Command Code string from the previous "CO" example and the data to write to the TAG.

The screenshot shows the "Message Setup" dialog box with the following configuration:

Section	Parameter	Value
General	Type	Peer-To-Peer
	Read/Write	Write
	Target Device	PLC5
	Local/Remote	Local
	Control Block	11:15
	Channel	0
	Target Node (decimal)	0 (0 Octal)
	Our Source File Address	N9:0
	Targets Destination File	N32:128
	Message Length in Elements	20
Message Timeout (Seconds)	0	
Control Bits	Ignore if timed out (TO)	0
	To be retired (NR)	0
	Awaiting Execution (EW)	0
	Continuous Run (CO)	0
	Error (ER)	0
	Message done (DN)	0
	Message Transmitting (ST)	0
	Message Enabled (EN)	0
	Waiting for queue space	0
	Control Address	11:15
Error	Error Code(Hex)	0
Error Description		

Buttons: OK, Cancel, Help

Reading from the "CO" Mode Buffer

The Typed Read Message Instruction is used to read the "CO" Mode Results Buffer into the SLC Data Table:

- 1. The Destination File Address is where the "CO" results are stored in the SLC.
- 2. The Size in Elements is the length in words contained in the "CO" Results Buffer. The Size of Elements must be 2 words greater than the number of words that previously was read allowing for 2 words of status.
- 3. The Target Source File Address is the "CO" Mode Results buffer address.
- 4. The Port Number is **Zero** for Channel 0.

The example below displays a Typed Read Message Instruction that reads 22 words from Channel #1 of the "CO" Mode Results Buffer at address N34:128 of BS-46. The data will be read to SLC File Address N9:50.

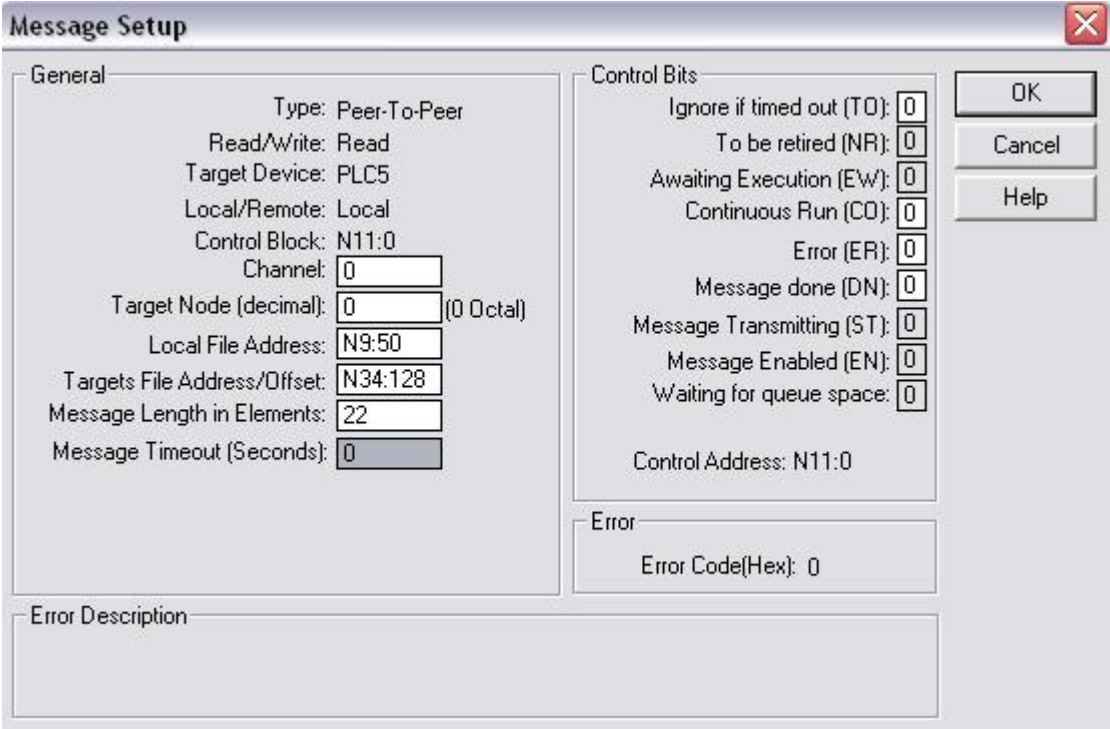

Results Buffer "CO" Mode

Word 1 High Byte = message type (values 3,4,5,6)

- If value is 3 = Command 1 for Channel #1
- If value is 4 = Command 1 for Channel #2
- If value is 5 = Command 2 for Channel #1
- If value is 6 = Command 2 for Channel #2

Low Byte = Event counter per message type (defined in High Byte)

Word 2 = 0, Correct message type

If not equal to zero, then fault type is contained in Low Byte

If Word 2 not equal to zero, then the following data is not valid

Word 3++ = Read or Written data

The example below displays the SLC Data File Addresses N9:50 that contains the "CO" Results Buffer of the previous example's "CO" Command Code of a Write operation. The High Byte of word N9:50 is a 03H. It shows Command 1 for Channel #1 was executed. The Low Byte of word N9:50 is a 02H, which means the results are from the second event for that "CO" Command Buffer. The SLC address N9:51 is of value 00H, which signifies there were no errors within the execution of the operation. Addresses N9:52 - N9:71 are the data values written to the TAG.

Offset	0	1	2	3	4	5	6	7	8	9
N9:0	2	3	14	5	101	101	101	101	101	101
N9:10	101	101	101	101	101	101	101	101	101	101
N9:20	101	101	101	101	0	0	0	0	0	0
N9:30	0	0	0	0	0	0	0	0	0	0
N9:40	0	0	0	0	0	0	0	0	0	0
N9:50	302	0	101	101	101	101	101	101	101	101
N9:60	101	101	101	101	101	101	101	101	101	101
N9:70	101	101								

Below the table, there is a search bar with 'N9:71' entered, a 'Radix' dropdown set to 'Decimal', a 'Columns' dropdown set to '10', and a 'Desc:' field. At the bottom, there are buttons for 'Properties', 'Usage', and 'Help', and a dropdown menu showing 'N9'.

Faults "CO" Mode

Low Byte "CO" Results Word 2 (If not equal to zero):

Fault Code "CO" Mode	Description
9FH	Dialogue Impossible to Complete
9CH	Transceiver fault
9EH	TAG Memory fault
9BH	Addressing error
90H	Configuration error

Operation "CO" Mode:

"CO" Operation Mode performs one command operation for each Channel. The operation is initiated by the command being sent on the serial link or setting a parallel input high when the TAG is present. Once the command is executed, the ENR output is set high. The "CO" Mode Results Buffer must be read to retrieve the data to the SLC and to reset the BS-46 to execute another "CO" Mode operation. After the "CO" Mode Results Buffer is read, the ENR output will be reset low.

Whichever "CO" Command Buffer is programmed first will execute first. Each "CO" Command Buffer operates separately from one another and each has its own event counter.

The "CO" Mode Results Buffer can contain the results of Command 1 or Command 2.

Channel	Output
Transceiver 1	Terminal A3 - ENR1
Transceiver 2	Terminal A7 - ENR2

Note: The BS-46 is not reset if the "CO" Mode Results Buffer is read short of data equal to the previous operation. After the results are read, the data is stored in the Historic Buffer. The "CO" Mode Results Buffer is reset to zero after the buffer is read, and is then ready for the next operation.

Serial Link Operation "CO" Mode

The serial link function does one operation per serial command. Once the operation has executed, another serial message must be sent to do another operation. The best use for the "CO" Mode serial link command is to perform a Read or Write TAG with Wait operation.

Example:

1. The "CO" Command Buffer 1 was sent a serial command to read a TAG with wait. Then, "CO" Command Buffer 2 was sent a serial command to write a TAG with wait.
 2. A TAG enters the Transceiver zone. Since it was programmed first, Command Buffer 1 executes a Read TAG command. ENR output goes high when the operation finishes.
- 3A. Condition 1:** The "CO" Results Buffer is read while the TAG is still in the Transceiver zone.
- Results 1:** The ENR output goes low, and the "CO" Command Buffer 2 Write TAG command executes. Once completed, the ENR output goes high and the "CO" Results Buffer must be read. Once the "CO" Results Buffer is read, no other operation will be performed until another serial message is sent to either Command Buffer.
- 3B. Condition 2:** The "CO" Results Buffer is read when the TAG has already left the Transceiver zone.
- Results 2:** The ENR output goes low and will stay low until another TAG enters the Transceiver zone. Once the TAG enters the Transceiver zone, the "CO" Command Buffer 2 Write TAG Command executes and the ENR output goes high. Once the "CO" Results Buffer is read, there will be no other operation performed until another serial message is sent to either Command Buffer.

Parallel Input Operation "CO" Mode

Once programmed, the Parallel "CO" Mode does repeated operations, until power is recycled or another command is sent. This Mode is useful when the orders of events require control.

Parallel Input to Trigger "CO" Command:

Channel	Input
Transceiver 1 Command 1	Terminal B2 - DCY11
Transceiver 1 Command 2	Terminal B3 - DCY12
Transceiver 2 Command 1	Terminal B6 - DCY21
Transceiver 2 Command 2	Terminal B7 - DCY22

Example:

1. The "CO" Command Buffer 1 is programmed to read a TAG without wait, when the parallel input Terminal B2 (DCY11) is set high. The "CO" Command Buffer 2 is programmed to write a TAG without wait when the parallel input Terminal B3 (DCY12) is set high.
2. A TAG enters the Transceiver zone. If DCY11 is set high, then the read operation will execute. If DCY12 is set high, then the write operation will execute.
3. After a command has been executed, both parallel inputs are without effect until the "CO" Results Buffer has been read.
4. If a TAG is present after the "CO" Results Buffer has been read, then another input can be set high to trigger either of the commands. If a TAG is not present after the "CO" Results Buffer has been read, then the inputs are without effect.

Note: A TAG must be present when the BS-46 is programmed for parallel input "CO" Mode to trigger the command into action. The TAG present output can be hard wired to a parallel input to trigger one of the "CO" Command Buffer's Command to execute each time a TAG arrives in station. The parallel inputs are without effect until the results of the previous command is read.

Operation

The BS-46 can operate in three different Modes: Direct Access ("DA"), Automatic Read ("AR") and Controlled Operating ("CO").

Question: Which Mode is best for my application?

Answer: More than one Mode may work for your application. For simplicity, "DA" Mode is the best. For Read-Only type applications where discontinuous block reads are needed, "AR" Mode may be the best. Applications where specific operations need conclusions of other operations, then "CO" Mode is useful.

Question: Can two or more Modes be programmed and operate at once?

Answer: Yes, all three Modes can be used at one station. If "AR" Mode and "CO" Mode are both programmed to do an operation when the TAG arrives, the first one carried out is the "AR" Mode, followed by the first programmed "CO" Mode Command Buffer's operation. "DA" Mode can be executed any time between or after the reading of the Results Buffer.

Data Formatting:

Data returned from a TAG Read is a "first read-first in" scheme. This means the TAG address byte read first (which is the Source File Address in the Typed Read Message Instruction) will appear in the first word's High Byte in the SLC's Data Table (which is the Destination File Address in the Typed Read Message Instruction). The same is true for a Write to a TAG. The High Byte of the first word in the SLC's Data Table (the Source File Address in the Typed Write Message Instruction), will be written to the first byte of the TAG beginning at the Target Destination File Address in the Typed Write Message Instruction used.

BALOGH

Serial Control Board BS-46/**

Identification - Coding

Reference: BS-46/**

A=	OMA	64, 2K, or 8K bytes Read/Write TAG
P=	OP	64 byte & 96 byte Read/Write
X=	OMX	High Speed 8K & 32K byte Read/Write TAG
E=	GIE	512, 2K, 8K byte Read/Write
F=	OF or OFR	7 bytes Read-Only TAG
L=	OL or OLR	2 bytes Extended Range Read-Only TAG

Characteristics

1 Isolated Serial Link	RS-485 With a 15 Pin Connector UNITELWAY® Compatible RS-422 or RS-232, with a 25 Pin Connector
Protocol Defined by Switches:	JBUS® / MODBUS®, UNITELWAY®, 3964R®, DF1®, and Allen Bradley DH+® on Channel Zero.
8 // Opto Isolated Displayed Inputs	
8 // Opto Isolated Displayed Outputs (TAG Presence, Fault Indication...)	
Dual Channel Interface: Drives Two Fully Independent Transceivers, with 2 Different Channel Control Ability.	
Configuration by switches for slave number, baud rate, parity and communication protocol.	

Characteristics	Symbol	Unit	BS-46
Supply Power ($\pm 10\%$)	UCC	V	24 (ripple <2%)
Consumed	Io	MA	70mA (Transceiver Consumption)
Ambient Temperature	T	°C	0 to 50° C
Protection Degree	IP	/	30
Weight	M	G	750 grams
//Outputs			
Max Continuous Current	Is	MA	200mA
Max Voltage	Us	V	55 Volts
Max Voltage Drop	Ud	V	2 Volts
//Inputs			
Max Voltage	Ue	V	55 Volts
Impedance	Ze	Kohms	5
Level "0"	Oe	V	0<U<8 Volts
Level "1"	1e	V	15<U<Ucc

DF1® & DH+® : Trademark of ALLEN BRADLEY
 MODBUS® : Trademark of GOULD MODICON
 JBUS® : Trademark of APRIL
 UNITELWAY® : Trademark of TELEMECANIQUE ELECTRIQUE
 3964R® : Trademark of SIEMENS
 SLC 503/504® : Trademark of ALLEN BRADLEY

Revised: October 11, 2002

Male 25 Pin Connector		Female 15 Pin Connector	
RS422	RS232	RS485	Slave Addressing
Pin 24=Rx- = Signal B			Pin 9 = N0
Pin 25=Rx+ = Signal A	Pin 3=Rx = Input	Pin 14 = Signal B	Pin 2 = N1
Pin 12=Tx- = Signal B	Pin 2=Tx = Output	Pin 7 = Signal A	Pin 10 = N2
Pin 11=Tx+ = Signal A	Pin 7 = 0 Volt	Pin 8/15 = 0 Volt	Pin 3 = N3
Pin 13 = 0 Volt			Pin 5 = Common

Left

No.	Low Terminal = B	No.	High Terminal = A	
B1	Common Terminal for Inputs*	A1	0 Volt	
B2	Input 1 = DCY11	A2	Output 1 = SURV	Channel #1
B3	Input 1 = DCY12	A3	Output 2 = ENR	
B4	Input 1 = DCY13	A4	Output 3 = DEF	
B5	Input 1 = DCY14	A5	Output 4 = PRE	
B6	Input 1 = DCY21	A6	Output 5 = SURV	Channel #2
B7	Input 1 = DCY22	A7	Output 6 = ENR	
B8	Input 1 = DCY23	A8	Output 7 = DEF2	
B9	Input 1 = DCY24	A9	Output 8 = PRE2	
B10	+ U Voltage *	A10	Common for Output	
B11	+ U Power supply	A11	0 Volt Power Supply	Power Supply
B12		A12	0 Volt	
B13	+ U Power Supply ->V or b1	A13	0 Volt ->O or b4	T/R#2
B14	Input -> S or b2	A14	Output -> E or b3	
B15		A15	0 Volt	
B16	+ U Power Supply -V or b1	A16	0 Volt ->O or b4	T/R#1
B17	Inputs -S or b2	A17	Output ->E or b3	
B18	/	A18	/	

Right

Note: 1) Connect B1 to A1 and B10 to A10 to provide power to LEDS

2) When using BALOGH Transceiver Cables: V is Brown, S is White, E is Blue, and O is Black.

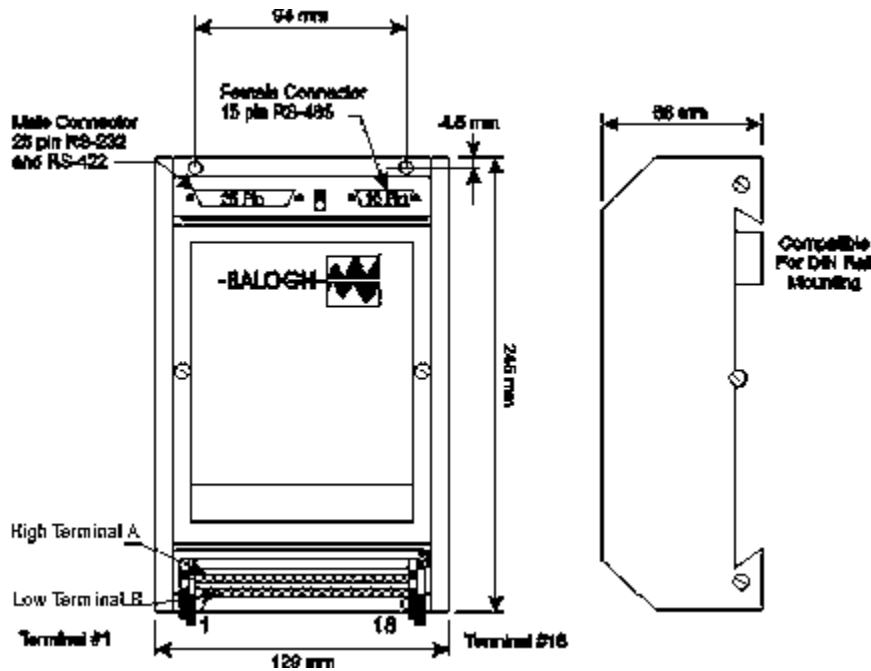

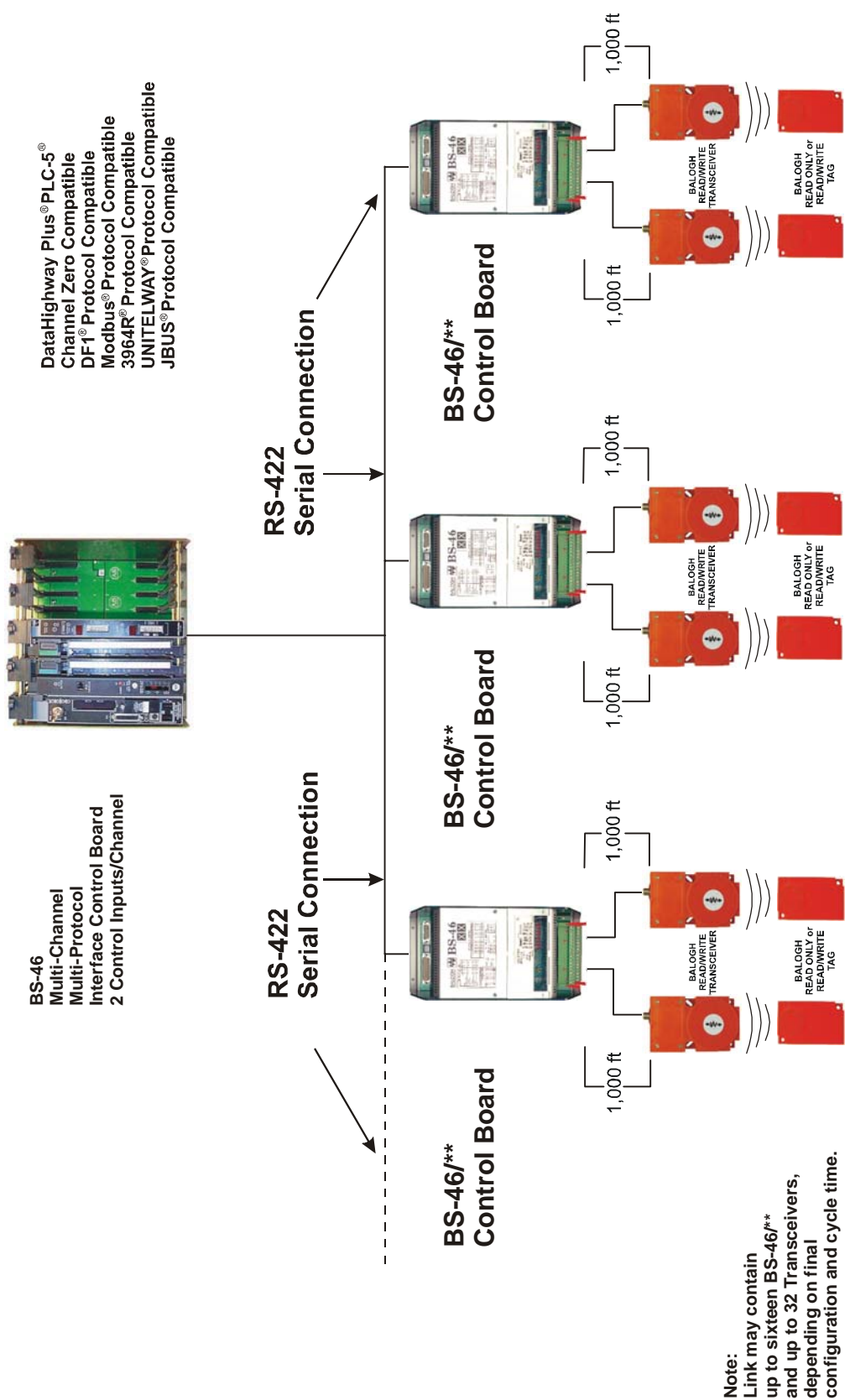

DataHighway Plus® PLC-5®
Channel Zero Compatible
DF1® Protocol Compatible
Modbus® Protocol Compatible
3964R® Protocol Compatible
UNITELWAY® Protocol Compatible
JBUS® Protocol Compatible

Note:
Link may contain
up to sixteen BS-46/**
and up to 32 Transceivers,
depending on final
configuration and cycle time.

© UNITELWAY is a registered trademark of the Telemecanique Corporation
 © JBUS is a registered trademark of the April Corporation
 © DF1, PLC-5 and Data Highway Plus is a registered trademark of the Allen Bradley Corporation
 © Modbus is a registered trademark of the Modicon Corporation
 © 3964R is a registered trademark of the Siemens Corporation

